

Amphenol 安费诺 2M801-009-07M9-19PA PDF

Amphenol

深圳创唯电子有限公司

<http://www.amphenol-connect.com>

Table of Contents

Section	Description	Pages
Contacts & Tools pg. 3-5	Crimp Contacts, Contact Tools, Crimp Tensile Strength	3
	Grommet Sealing Plugs	4
	Spanner Tools for Tightening Jam Nuts	5
	Holding Tool Tightening Backshells Accessories	
	2M Torque Values	
Insert Arrangements pg. 6-9	Insert Arrangement Chart	6
	Insert Arrangement Patterns	7-9
2M Specifications pg. 10-18	Performance Specs, Material & Finishes	10
	Complete Product Specifications	11-16
2M801 Dual Start Section pg. 17-31	General Information	17
	Connector Weights	18
	Ordering Guide for 2M801-007, 008, 009, 010	19
	2M801-007 & 2M801-008	20
	2M801-009-07 & 2M801-010-07	21
	2M801-009-02 & 2M801-010-02	22
	2M801-009-01 & 2M801-010-01	23
	Ordering Guide for 2M801-011, 2M801-033	24-25
	Ordering Guide for 2M801-012	26
	Hermetic Jam Nut 2M801-012-07	27
2M801 Dual Start - PC Board pg. 24-25	Hermetic Square Flange 2M801-012-02	28
	Hermetic Solder Mount 2M801-012-03	29
	Ordering Guide for 2M667-217 & 218	30-31
2M803 1/4 Turn Bayonet Section pg. 32-44	General Information	32
	Connector Weights	33
	Ordering Guide for 2M803 Crimp Receptacles & Plugs	34
	2M803-001-06 & 2M803-002-06 Plug	35
	2M803-003-07, 2M803-004-07 Jam Nut	36
	2M803-003-02, 2M803-004-02 Flange Mount	37
	2M803-003-01 & 004-01, In-Line	38
	Ordering Guide for 2M803-005, 2M803-015	39-40
	Ordering Guide for 2M803-006 1/4 Turn Bayonet - Hermetic	41
	2M803-006-02 & 07 Flange Mount and Jam Nut	42
2M803 1/4 Turn Bayonet - PC Board Receptacles pg. 39-40	Ordering Guide for 2M660-082 & 2M660-083	43
	Protection Caps	44
2M803 1/4 Turn Bayonet - Hermetic Receptacles pg. 41-42	General Information	45
	Connector Weights	46
2M804 Push-Pull Section pg. 45-64	Ordering Guide for 2M804-001, 002, 003, 004	47
	2M804-001-06, 2M804-002-06 Plug	48
	2M804-004-07, 2M804-003-07 Jam Nut Rear Panel	49
	2M804-004-00, 2M804-003-00 Jam Nut Front Panel	50
	2M804-004-01, 2M804-003-01 In-Line Receptacle	51
	Ordering Guide for 2M804 Push-Pull PC Board Receptacles	52
	2M804-005-07, 2M804-020-07 Rear Panel Jam Nut Receptacles	53
	2M804-005-00, 2M804-020-00 Push Pull PCB or Solder Cup	54
	Ordering Guide for 2M804-009, 2M804-021	55
	2M804-009-07, 2M804-021-07 Jam Nut Panel Mount	56
2M804 Push-Pull PC Board Receptacles pg. 52-54	2M804-009-00, 2M804-021-00 Jam Nut Receptacle	57
	2M804-009-02, 2M804-021-02 Plug Flange Panel Mount	58
	Ordering Guide for 2M804-006 Rear Panel Jam Nut Hermetic	59
2M804 Push-Pull Plug Panel Mount pg. 55-58	2M804-006-07 Rear Panel Jam Nut Hermetic	60
	2M804-006-00 Front Panel Jam Nut Hermetic	61
	Ordering Guide for 2M667-202 Protection Caps	62
2M804 Push-Pull Hermetic Receptacle pg. 59-61	Ordering Guide for 2M809-198 Protection Caps	63
	2M809-198, 2M667-202	64
	2M804 Push Pull Plug Rubber Caps	65-66
	General Information	67
2M804 Push-Pull Plug Protection Caps pg. 62-64	Connector Weight in Grams	68
	Ordering Guide for 2M805 Plug & Receptacles	69
	2M805-001, 2M805-002 Plug	70
	2M805-003-01, 2M805-004-01 In-Line Receptacle	71
	2M805-003-02, 2M805-004-02 Square Flange Receptacle	72
	2M805-003-07, 2M805-004-07 jam Nut Receptacle	73
	Ordering Guide for 2M805-005, 2M805-017	74
	2M805-005-02, 2M805-017-02 PC Tail-Solder Cup Square Flange	75
	2M805-005-07, 2M805-017-07 PC Tail-Solder Cup Jam Nut	76
	Order Guide for 2M805-006	77
2M805 Tri-Start Threaded Coupling Section pg. 67-82	2M805-006-02 Tri-Start Flange Mount Hermetic	78
	2M805-006-03 Tri-Start Solder Mount Hermetic	79
	2M805-006-07 Tri-Start Jam Nut Hermetic	80
2M805 Tri-Start PCB or Solder Cup Receptacle pg. 74-76	2M667-261, 2M667-262	81-82
	Advantages & Characteristics	83-84
2M805 Tri-Start Hermetic Receptacle pg. 77-80	Shrink Boots, Hex Nuts, Flange Gaskets, Strain Relief Clamps, Backshells	85-102
2M805 Tri-Start Protection Cap pg. 81-82		
2M Filter High Density Connectors pg. 83-84		
2M Backshells & Accessories pg. 85-102		

2M Series Selection Table

2M801, 2M803, 2M804 and 2M805



SERIES	2M801	2M803	2M804	2M805
TYPE	Dual-Start ACME Thread	Bayonet	Push-Pull	Tri-Start ACME Thread
DESCRIPTION	More rugged keys and threads. Faster mating.	Quick-mating, light duty, general purpose. Not rated for immersion, 50 milliohms shell-to-shell resistance.	Breakaway connector for headsets and tactical equipment. Gold-plated spring for long mating life and superior EMI shielding.	"Anti Decoupling" ratchet mechanism and ground spring for military airframes and avionics boxes. Fast mating.
CONTACTS	1 to 130	1 to 55	1 to 55	1 to 130
COUPLING	Threaded Coupling with 1 1/2 Turns to Full Mate	1/4 turn lock Bayonet	Push, Pull Quick-Disconnect	Tri-Start Thread
WATER IMMERSION, MATED	MIL-STD-810 Method 512 1 Meter for 1 Hour	Splashproof	MIL-STD-810 Method 512 1 Meter for 1 Hour	MIL-STD-810 Method 512 1 Meter for 1 Hour
EMI SHIELDING	Good	Fair	Very Good	Excellent
VIBRATION AND SHOCK	37 g's Random Vibration; 300 g's Shock	37 g's Random V ibration; 300 g's Shock	37 g's Random Vibration; 300 g's Shock	37 g's Random Vibration; 300 g's Shock
MATING CYCLES	2000 Cycles	250 Cycles Aluminum 2000 Cycles Stainless Steel	2000 Cycles	500 Cycles
ELECTRICAL PERFORMANCE	#12: 23 AMP, 1800 VAC #16: 13 AMP, 1800 VAC #20: 17.5 AMP, 750 VAC #23: 5 AMP, 500 VAC	#12: 23 AMP, 1800 VAC #16: 13 AMP, 1800 VAC #20: 17.5 AMP, 750 VAC #23: 5 AMP, 500 VAC	#12: 23 AMP, 1800 VAC #16: 13 AMP, 1800 VAC #20: 17.5 AMP, 750 VAC #23: 5 AMP, 500 VAC	#12: 23 AMP, 1800 VAC #16: 13 AMP, 1800 VAC #20: 17.5 AMP, 750 VAC #23: 5 AMP, 500 VAC
FILTERED	See page 83 and 84	See page 83 and 84	See page 83 and 84	See page 83 and 84

Crimp Contacts

Contact Size	Type	AMPS	Wire Size AWG	AAO Part number	Military Part number	Color Band		
						1st	2nd	3rd
#23	Pin	5	#22-#28	10-597346-735	N/A	N/A	N/A	N/A
	Pin		#26-#30	10-597346-745	N/A	Blue	N/A	N/A
	Socket		#22-#28	10-597345-735	N/A	N/A	N/A	N/A
	Socket		#26-#30	10-597345-745	N/A	Blue	N/A	N/A
#20HD	Pin	7.5	#20-#24	10-688615-015	N/A	N/A	N/A	N/A
	Socket		#20-#24	10-688616-015	N/A	N/A	N/A	N/A
#20	Pin	7.5	#20-#24	10-251415-020	M39029/58-363	Orange	Blue	Orange
	Socket		#20-#24	10-251416-020	M39029/57-357	Orange	Green	Violet
#16	Pin	7.5	#16-#20	10-251415-016	M39029/58-364	Orange	Blue	Orange
	Socket		#16-#20	10-251416-016	M39029/57-358	Orange	Green	Gray
#12	Pin	23	#12-#14	10-251415-012	M39029/58-365	Orange	Blue	Green
	Socket		#12-#14	10-251416-012	M39029/57-359	Orange	Green	White

Contact Tools

Contact Size	Tooling Part Numbers				
	Crimper	Positioner	Insertion Number (Metal Tools)	Removal (Metal Tools)	Military Insertion/ Removal Number (Plastic Tools)
#23	M22520/2-01	M22520/2-12	See Daniels #	See Daniels #	DAK225-22 (Daniels Insertion Only) DRK225-22 (Daniels Removal Only)
#20HD	M22520/2-01	2M809-206	N/A	N/A	N/A
#20	M22520/1-01	M22520/1-04	11-008674-020	11-008675-020	M81969/14-10
#16	M22520/1-01	M22520/1-04	11-008674-016	11-008675-016	M81969/14-03
#12	M22520/1-01	M22520/1-04	11-008674-012	11-008675-012	M81969/14-04

Crimp Tensile Strength

Contact Size	Wire Gage	Silver or Tin Coated Copper Wire	Nickel Coated Copper Wire
#23, #20HD	#22	12	8
#23, #20HD	#24	8	6
#23	#26	5	3
#23	#28	3	2
#23	#30	1.5	1.5

Tensile Strength for size #23 and #20HD only
Values represent minimums and are in pounds

Grommet Sealing Plugs

Size	Color	Part Number	Military Part Number
#23	Black	2M809-155	(None)
#20	Red	2M859-012	MS27488-20-2
#16	Green	2M859-013	MS27488-16-2
#12	Orange	2M859-014	MS27488-12-2

Spanner Tool for Tightening Series 2M Jam Nuts

Shell Size	Holding Tool Part Number (Add P or R)				
	Series 2M801	Series 2M803	Series 2M804 Style 07	Series 2M804 Style 00	Series 2M805
5	2M600-146-02	2M600-137-05	2M600-146-03	2M600-147-05	
6	2M600-146-03	2M600-137-06	2M600-146-04	2M600-147-06	
7	2M600-146-05	2M600-137-07	2M600-146-06	2M600-147-07	
8	2M600-146-05	2M600-137-08	2M600-146-06	2M600-147-07	2M600-154-08
9	2M600-146-06	2M600-137-09	2M600-146-07	2M600-147-09	2M600-154-09
10	2M600-146-07	2M600-137-10	2M600-146-08	2M600-147-10	2M600-154-09
11					2M600-154-11
12		2M600-137-12	2M600-141-10	2M600-147-12	2M600-154-12
13	2M600-146-10				
14		2M600-137-14	2M600-141-12	2M600-147-14	
15		2M600-137-15	2M600-141-13	2m600-147-15	2M600-154-15
16	2M600-146-13				
17	2M600-146-14				
18					2M600-154-18
19					2M600-154-19
21	2M600-146-17				
23					2M600-154-23

Connector Holding Tool for Tightening Backshells Accessories

Shell Size	Holding Tool Part Number (Add P or R)				
	Series 2M801		Series 2M803	Series 2M804	Series 2M805
5	2M600MM005-05	•	2M600-140-5	> 2M600-141-5	×
6	2M600MM005-06	•	2M600-140-6	> 2M600-141-6	×
7	2M600MM005-07	•	2M600-140-7	> 2M600-141-7	×
8	2M600MM005-08	•	2M600-140-8	> 2M600-141-8	×
9	2M600MM005-06	•	2M600-140-9	> 2M600-141-9	×
10	2M600MM005-10		2M600-140-10	2M600-141-10	×
11					2M600-155-11
12			2M600-140-12	> 2M600-141-12	×
13	2M600MM005-13	•			2M600-155-12
14			2M600-140-14	> 2M600-141-14	×
15			2M600-140-15	> 2M600-141-15	×
16	2M600MM005-16	•			
17	2M600MM005-17	•			
18					2M600-155-18
19					2M600-155-19
21	2M600MM005-21	•			
23					2M600-155-23

• Add P for plug holder or R for receptacle holder, followed by polarizing position (N, X, Y, Z)

> Add P for Plug holder or R for Receptacle holder, followed by polarizing position (A, B, C, D).

×

× Add P for Plug holder or R for Receptacle holder.

Series 2M Torque Values

SERIES 2M801, 2M803, 2M805 RECOMMENDED TORQUE VALUES

Shell Size Series 2M801, 2M803	Shell Size Series 2M805	Coupling Torque				Jam Nut Tightening				Backshell Tightening			
		In-LBs.		N-m		In-LBs.		N-m		In-LBs.		N-m	
		Min.	Max.	Min.	Max.	Min.	Max.	Min.	Max.	Min.	Max.	Min.	Max.
5	-	25	35	2.8	4.0	20	25	2.2	2.8	13	17	1.5	1.9
6	8	35	40	4.0	4.5	20	25	2.2	2.8	18	22	2.0	2.5
7	9	35	40	4.0	4.5	20	25	2.2	2.8	30	40	3.4	4.5
8	10	40	50	4.5	5.7	20	25	2.2	2.8	30	40	3.4	4.5
9	11	40	50	4.5	5.7	20	25	2.2	2.8	35	45	4.0	5.1
10	12	50	60	5.7	6.8	25	30	2.8	3.3	35	45	4.0	5.1
12, 13	15	50	60	5.7	6.8	25	30	2.8	3.3	35	45	4.0	5.1
14, 16	18	55	65	6.2	7.3	25	30	2.8	3.3	35	45	4.0	5.1
15, 17	19	55	65	6.2	7.3	25	30	2.8	3.3	35	45	4.0	5.1
21	23	55	65	6.2	7.3	25	30	2.8	3.3	35	45	4.0	5.1

SERIES 2M INSERT ARRANGEMENTS

Contact Size	Contact Quantity					Insert Arrangement			
	#23	#20	#20HD	#16	#12	2M801	2M803	2M804	2M805
Size #23 Contacts 5 Amp Max. Current 500 VAC #23-#28 AWG	3					5-3	5-3	5-3	NA
	4					6-4	6-4	6-4	8-4
	6					6-6	6-6	6-6	8-6
	7					6-7	6-7	6-7	8-7
	10					7-10	7-10	7-10	9-10
	13					8-13	8-13	8-13	10-13
	19					9-19	9-19	9-19	11-19
	26					10-26	10-26	10-26	12-26
	37					13-37	12-37	12-37	15-37
	55					16-55	14-55	14-55	18-55
85					17-85	NA	NA	19-85	
130					21-130	NA	NA	23-130	
Size #20HD Contacts 7.5 Amp Max. Current 750 VAC #20-#24 AWG.			3			6-23	6-23	6-23	8-23
			5			7-25	7-25	7-25	9-25
			8			8-28	8-28	8-28	10-28
			10			9-210	9-210	9-210	11-210
			20			13-220	12-220	12-220	15-220
			35			16-235	14-235	14-235	18-235
			41			17-241	NA	NA	19-241
		69			21-269	NA	NA	23-269	
Size #16 Contacts 13 Amp Max. Current 1800 VAC #16-#20 AWG				1		6-1	6-1	6-1	8-1
				2		8-2	8-2	8-2	10-2
				4		9-4	9-4	9-4	11-4
				5		10-5	10-5	10-5	12-5
				7		13-7	12-7	12-7	15-7
				12		16-12	14-12	14-12	18-12
				14		17-14	NA	NA	19-14
			22		21-22	NA	NA	23-22	
Size #12 Contacts 23 Amp Max. Current 1800 VAC #12-14 AWG					1	7-1	7-1	7-1	9-1
					2	10-2	10-2	10-2	12-2
					2	13-2	12-2	12-2	15-2
					3	13-3	12-3	12-3	15-3
					5	16-5	14-5	14-5	18-5
					7	17-7	NA	NA	19-7
				12	21-12	NA	NA	23-12	
Insert Arrangements with Mixed Size (Combo) Layouts	4	2				8-200	8-200	8-200	10-200
	8	2				9-201	9-201	9-201	11-201
	4			2		9-200	9-200	9-200	11-200
	8			2		10-202	10-202	10-202	12-202
	4				2	10-201	10-201	10-201	12-201
	6				2	13-200	12-200	12-200	15-200
	10				2	13-201	12-201	12-201	15-201
	12				1	10-200	10-200	10-200	12-200

Insert Arrangements

Front face of pin inserts illustrated (Socket Reversed)

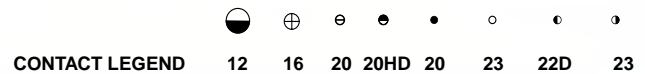

2M Specs

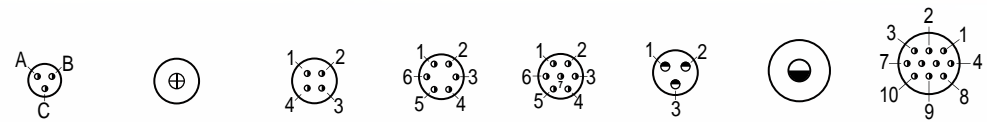

2M801, 2M803, 2M804	5-3	6-1	6-4	6-6	6-7	6-23	7-1	7-10
2M805	NA	8-1	8-4	8-6	8-7	8-23	9-1	9-10
No. of Contacts	3	1	4	6	7	3	1	10
Contact Size	#23	#16	#23	#23	#23	#20HD	#12	#23
DWV Voltage (VAC)	500	1800	500	500	500	750	1800	500
Current Rating (Amps)	5	13	5	5	5	7.5	23	5

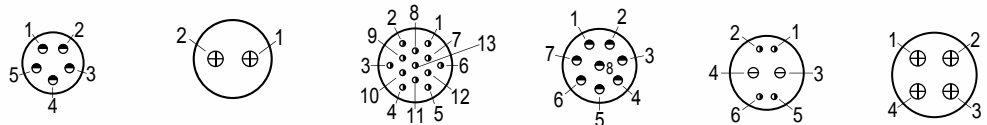

2M801, 2M803, 2M804	7-25	8-2	8-13	8-28	8-200	9-4
2M805	9-25	10-2	10-13	10-28	10-200	11-4
No. of Contacts	5	2	13	8	2 4	4
Contact Size	#20HD	#16	#23	#20HD	#20 #23	#16
DWV Voltage (VAC)	750	1800	500	750	1000 500	1800
Current Rating (Amps)	7.5	13	5	7.5	7 5	13

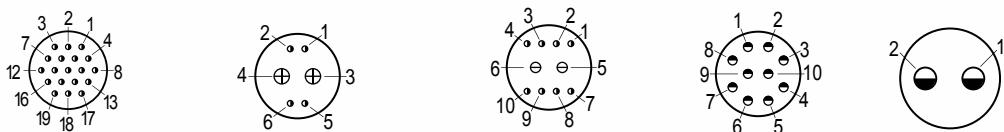

2M801, 2M803, 2M804	9-19	9-200	9-201	9-210	10-2
2M805	11-19	11-200	11-201	11-210	12-2
No. of Contacts	19	2	4	2 8	10
Contact Size	#23	#16	#23	#20 #23	#20HD #12
DWV Voltage (VAC)	500	1800	500	1000 500	750 1800
Current Rating (Amps)	5	13	5	7.5 5	7.5 23



2M801, 2M803, 2M804	10-5	10-201	10-202	10-200
2M805	12-5	12-201	12-202	12-200
No. of Contacts	5	2	4	2 8
Contact Size	#16	#12	#23	#16 #23
DWV Voltage (VAC)	1800	1800	500	1800 500
Current Rating (Amps)	13	23	5	13 5

Insert Arrangements

Front face of pin inserts illustrated (Socket Reversed)

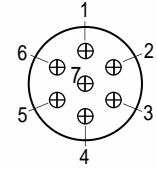
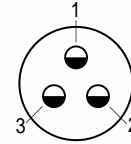
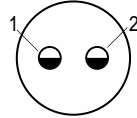
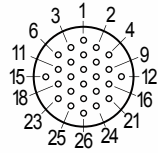
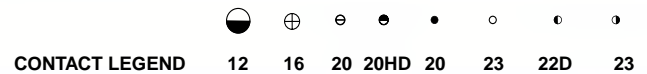

2M801	10-26	13-2	13-3	13-7
2M803, 2M804	10-26	12-2	12-3	12-7
2M805	12-26	15-2	15-3	15-7
No. of Contacts	26	2	3	7
Contact Size	#23	#12	#12	#16
DWV Voltage (VAC)	500	1800	1800	1800
Current Rating (Amps)	5	23	23	13

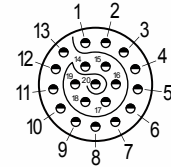
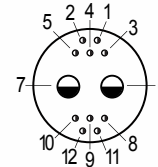
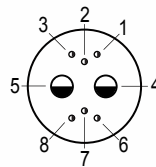
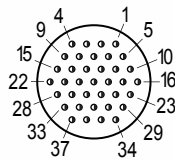

2M801	13-37	13-200	13-201	13-220		
2M803, 2M804	12-37	12-200	12-201	12-220		
2M805	15-37	15-200	15-201	15-220		
No. of Contacts	37	2	6	2	10	20
Contact Size	#23	#12	#23	#12	#23	#20HD
DWV Voltage (VAC)	500	1800	500	1800	500	750
Current Rating (Amps)	5	23	5	23	5	7.5

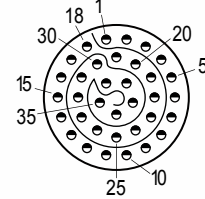
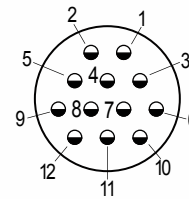
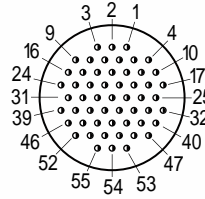
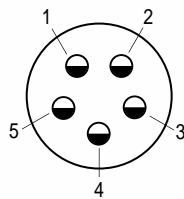

2M801	16-5	16-55	16-12	16-235
2M803, 2M804	14-5	14-55	14-12	14-235
2M805	18-5	18-55	18-12	18-235
No. of Contacts	5	55	12	35
Contact Size	#12	#23	#16	#20HD
DWV Voltage (VAC)	1800	500	1800	750
Current Rating (Amps)	23	5	13	7.5

2M Specs

Insert Arrangements

Front face of pin inserts illustrated (Socket Reversed)

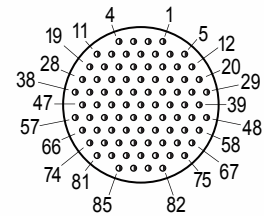
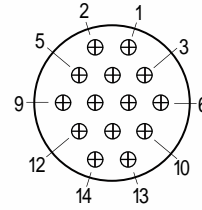
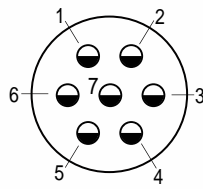
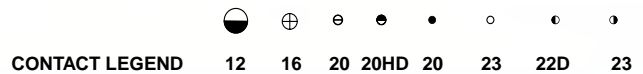

2M801	17-7	17-14	17-85
2M805	19-7	19-14	19-85
No. of Contacts	7	14	85
Contact Size	#12	#16	#23
DWV Voltage (VAC)	1800	1800	500
Current Rating (Amps)	23	13	5

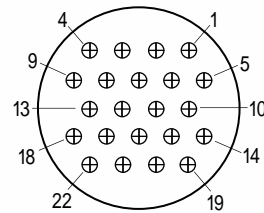
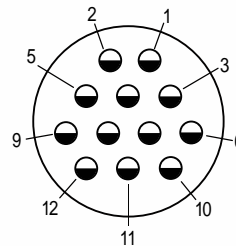
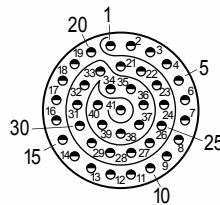

2M801	17-241	21-12	21-22
2M805	19-241	23-12	23-22
No. of Contacts	41	12	22
Contact Size	#20HD	#12	#16
DWV Voltage (VAC)	750	1800	1800
Current Rating (Amps)	7.5	23	13

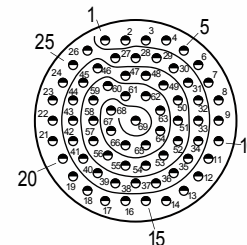
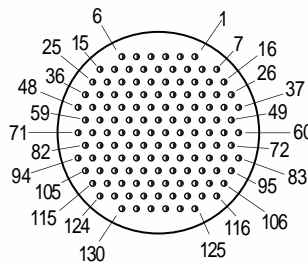

2M801	21-130	21-269
2M805	23-130	23-269
No. of Contacts	130	69
Contact Size	#23	#20HD
DWV Voltage (VAC)	500	750
Current Rating (Amps)	5	7.5

2M Specs

PERFORMANCE SPECIFICATIONS

Current Rating (Maximum)	Size #23 Contact: 5 AMPS. Size #20 contact: 7.5 AMPS. Size #16 contact: 13 AMPS. Size #12 contact: 23 AMPS.
Test Voltage (Dielectric Withstanding Voltage) Mated Connectors	Size #23 contacts: 500 VAC RMS sea level, 100 VAC RMS 40,000 feet Size #20 contacts: 1800 VAC RMS sea level, 325 VAC RMS 40,000 feet Size #20HD contacts: 750 VAC RMS sea level, 150 VAC RMS 40,000 feet Size #16 contacts: 1800 VAC RMS sea level, 1000 VAC RMS 40,000 feet Size #12 contacts: 1800 VAC RMS sea level, 1000 VAC RMS 40,000 feet
Insulation Resistance	5000 megohms minimum
Contact Resistance	Size #23 Contact: 73 millivolt drop at 5 AMPS. test current Size #20 contact: 55 millivolt drop at 7.5 AMPS. test current Size #16 contact: 49 millivolt drop at 13 AMPS. test current Size #12 contact: 42 millivolt drop at 23 AMPS. test current
Operating Temperature	-55° C. to +150° C.
Immersion, Mated	1 meter water immersion for 1 hour (2M803 Series splashproof only)
Shock	300 g
Vibration	37 g
Magnetic Permeability	2.0 μ maximum
Please refer to the comprehensive 2M Series Product Specification for additional parameters and test methods. Filter and Hermetic designs have different specifications. (Please refer to individual sections)	

MATERIALS AND FINISHES

Aluminum Shell, Barrel, and Coupling Nut	Aluminum alloy 6061 T6
Stainless Steel Shell, Barrel Coupling Nut	Passivated Stainless Steel, 200° C
Front and Rear Inserts	Polyphenylene Sulfide (PPS)
Contact Retention Clip	Beryllium copper, heat-treated, unplated
Grommet, Peripheral Seal and Interfacial Seal	Fluorosilicone Rubber
Contacts	Gold Plated Copper alloy
Socket Contact Hood	Passivated Stainless steel
Adhesives	Epoxy Film
Potting Compound, PCB and Solder Cup Versions	High Strength Epoxy

2M Series Technical Reference

Complete Product Specifications

2M Specs

DESCRIPTION	REQUIREMENT	PROCEDURE
ELECTRICAL		
Contact resistance	SAE AS39029 Table V	EIA-364-06 Test current in amperes. Voltage drop in millivolts. Silver-coated copper wire, +25°C.
	Wire Test Max <u>Size</u> <u>Current</u> <u>Voltage</u> <u>Drop</u>	
	12 23 42	
	14 17 40	
	16 13 49	
	20 7.5 55	
	22 5 73	
	24 3 45	
Low level contact resistance	Wire Max. <u>Size</u> <u>Milliohms</u>	EIA-364-23 100 milliamperes maximum and 20 millivolts maximum open circuit voltage
	16 5	
	20 9	
	22 15	
	24 20	
	26 31	
Insulation resistance	5000 megohms minimum	EIA-364-21 500 volts DC ± 50 volts. Test between adjacent contacts and contacts to shell.
	No breakdown or flashover #23 contacts 500 volts #20HD contacts 750 volts #16 contacts 1800 volts #12 contacts 1800 volts	EIA-364-20 AC rms 60 Hz. One minute dwell. Unmated or mated
Dielectric withstanding voltage, 40,000 feet altitude	No breakdown or flashover #23 contacts 100 volts #20HD contacts 150 volts #16 contacts 1000 volts #12 contacts 1000 volts	EIA-364-20 AC rms 60 Hz. One minute dwell. mated condition
	Current carrying capacity	EIA-364-70 Method 1
	Contact Max <u>Size</u> <u>Current</u> 12 23 16 13 20 7.5 23 5	

DESCRIPTION	REQUIREMENT	PROCEDURE																							
Shell-to-shell conductivity, Initial	The maximum voltage drop across a mated pair shall not exceed the values shown. <table border="1"> <thead> <tr> <th>Series</th> <th>Voltage Drop</th> </tr> </thead> <tbody> <tr> <td>2M801</td> <td>10</td> </tr> <tr> <td>2M803</td> <td>100</td> </tr> <tr> <td>2M804</td> <td>2</td> </tr> <tr> <td>2M805</td> <td>2</td> </tr> </tbody> </table>	Series	Voltage Drop	2M801	10	2M803	100	2M804	2	2M805	2	EIA-364-83 IEC-60512-2-6 Electroless nickel plated connectors.													
Series	Voltage Drop																								
2M801	10																								
2M803	100																								
2M804	2																								
2M805	2																								
Shell-to-shell conductivity, after conditioning (48 hours salt spray)	The maximum voltage drop across a mated pair shall not exceed the values shown. <table border="1"> <thead> <tr> <th>Series</th> <th>Voltage Drop</th> </tr> </thead> <tbody> <tr> <td>2M801</td> <td>20</td> </tr> <tr> <td>2M803</td> <td>200</td> </tr> <tr> <td>2M804</td> <td>4</td> </tr> <tr> <td>2M805</td> <td>4</td> </tr> </tbody> </table>	Series	Voltage Drop	2M801	20	2M803	200	2M804	4	2M805	4	EIA-364-83 IEC-60512-2-6 Electroless nickel plated connectors.													
Series	Voltage Drop																								
2M801	20																								
2M803	200																								
2M804	4																								
2M805	4																								
Shielding effectiveness, low frequency (100MHz-1000 MHz)	<table border="1"> <thead> <tr> <th rowspan="2">Frequency</th> <th colspan="2">dB Min. Attenuation</th> </tr> <tr> <th>Series 2M801, 2M804, 2M805</th> <th>Series 2M803</th> </tr> </thead> <tbody> <tr> <td>100 MHz</td> <td>75</td> <td>60</td> </tr> <tr> <td>200 MHz</td> <td>70</td> <td>55</td> </tr> <tr> <td>300 MHz</td> <td>65</td> <td>55</td> </tr> <tr> <td>400 MHz</td> <td>63</td> <td>50</td> </tr> <tr> <td>800 MHz</td> <td>58</td> <td>45</td> </tr> <tr> <td>1000 MHz</td> <td>55</td> <td>40</td> </tr> </tbody> </table>	Frequency	dB Min. Attenuation		Series 2M801, 2M804, 2M805	Series 2M803	100 MHz	75	60	200 MHz	70	55	300 MHz	65	55	400 MHz	63	50	800 MHz	58	45	1000 MHz	55	40	EIA-364-21 IEC-60512-3-1 500 volts DC \pm 50 volts. Test between adjacent contacts and contacts to shell.
Frequency	dB Min. Attenuation																								
	Series 2M801, 2M804, 2M805	Series 2M803																							
100 MHz	75	60																							
200 MHz	70	55																							
300 MHz	65	55																							
400 MHz	63	50																							
800 MHz	58	45																							
1000 MHz	55	40																							
Shielding effectiveness, high frequency (1Ghz-10GHz)	<table border="1"> <thead> <tr> <th rowspan="2">Frequency</th> <th colspan="2">dB Min. Attenuation</th> </tr> <tr> <th>Series 2M801, 2M804</th> <th>Series 2M805</th> </tr> </thead> <tbody> <tr> <td>1 GHz</td> <td>55</td> <td>85</td> </tr> <tr> <td>3 GHz</td> <td>50</td> <td>69</td> </tr> <tr> <td>5 GHz</td> <td>45</td> <td>66</td> </tr> <tr> <td>19 GHz</td> <td>40</td> <td>65</td> </tr> </tbody> </table>	Frequency	dB Min. Attenuation		Series 2M801, 2M804	Series 2M805	1 GHz	55	85	3 GHz	50	69	5 GHz	45	66	19 GHz	40	65	EIA-364-66 IEC-60512-23-3 Electroless nickel plated connectors						
Frequency	dB Min. Attenuation																								
	Series 2M801, 2M804	Series 2M805																							
1 GHz	55	85																							
3 GHz	50	69																							
5 GHz	45	66																							
19 GHz	40	65																							

2M Series Technical Reference

Complete Product Specifications

2M Specs

DESCRIPTION	REQUIREMENT	PROCEDURE
MECHANICAL		
Vibration, Sine	No discontinuity of greater than 1 microseconds, no cracking, breaking or loosening of parts, plug shall not become disengaged from receptacle. Connectors shall meet electrical requirements after vibration test.	MIL-STD-202 Method 204, test Condition G 12 sweep cycles per axes, 20 min. per 10-2000-10Hz
Vibration, Random	No discontinuity of greater than 1 microseconds, no cracking, breaking or loosening of parts, plug shall not become disengaged from receptacle. Connectors shall meet electrical requirements after vibration test.	EIA-364-28 Test Condition V Letter I 100 milliamp test current 50- 2,000 Hz 37.80 g rms
Gunfire Vibration	No discontinuity of greater than 1 microseconds, no cracking, breaking or loosening of parts, plug shall not become disengaged from receptacle. Connectors shall meet electrical requirements after vibration test.	MIL-STD-810F Method 519.5
Mechanical Shock	No discontinuity of greater than 1 microsecond, no cracking, breaking or loosening of parts, plug shall not become disengaged from receptacle. Connectors shall meet electrical requirements after shock test.	EIA-364-27 Condition D 300 G, halfsine, 3ms, 3 axes
Mechanical durability, at ambient temperature	No deterioration which will adversely affect the connector after 2000 cycles of mating and unmating. Connectors shall meet contact resistance, insulation resistance, shell-to-shell resistance, DWV, and mating and unmating force.	EIA-364-09
Solderability, PC tail contacts	95% solder coverage. Smooth, bright and even finish.	EIA-364-52 Category 3 8 hours steam aging prior to test 245° C, 4-5 sec. dwell 10X magnification
Resistance To Soldering Heat	No damage to connector. Connectors shall meet insulation resistance and waterproof sealing requirements.	EIA-364-56 260° C, 10 seconds (PC tail)

DESCRIPTION	REQUIREMENT	PROCEDURE																														
Impact	No impairment of function. Connector shall meet contact resistance, insulation resistance and waterproof sealing.	EIA-364-42 1 meter 8 drops																														
Contact retention	<table border="1"> <thead> <tr> <th>Contact Size</th> <th>Min. Pounds</th> <th>Min. Newtons</th> </tr> </thead> <tbody> <tr> <td>23</td> <td>6</td> <td>27</td> </tr> <tr> <td>20</td> <td>15</td> <td>67</td> </tr> <tr> <td>20HD</td> <td>9</td> <td>40</td> </tr> <tr> <td>16</td> <td>25</td> <td>111</td> </tr> <tr> <td>12</td> <td>25</td> <td>111</td> </tr> </tbody> </table>	Contact Size	Min. Pounds	Min. Newtons	23	6	27	20	15	67	20HD	9	40	16	25	111	12	25	111	EIA-364-29												
Contact Size	Min. Pounds	Min. Newtons																														
23	6	27																														
20	15	67																														
20HD	9	40																														
16	25	111																														
12	25	111																														
Contact separation force	<table border="1"> <thead> <tr> <th>Contact Size</th> <th>Min. Ounces</th> <th>Min. Newtons</th> </tr> </thead> <tbody> <tr> <td>23</td> <td>0.5</td> <td>0.14</td> </tr> <tr> <td>20</td> <td>0.7</td> <td>0.19</td> </tr> <tr> <td>16</td> <td>2.0</td> <td>0.56</td> </tr> <tr> <td>12</td> <td>3.0</td> <td>0.83</td> </tr> </tbody> </table>	Contact Size	Min. Ounces	Min. Newtons	23	0.5	0.14	20	0.7	0.19	16	2.0	0.56	12	3.0	0.83	SAE AS39029															
Contact Size	Min. Ounces	Min. Newtons																														
23	0.5	0.14																														
20	0.7	0.19																														
16	2.0	0.56																														
12	3.0	0.83																														
Coupling torque	Threaded coupling connector coupling torque shall not exceed the following requirements. <table border="1"> <thead> <tr> <th colspan="3">Shell Size</th> </tr> <tr> <th>Series 2M801</th> <th>Series 2M805</th> <th>Inch Pounds</th> </tr> </thead> <tbody> <tr> <td>5, 6, 7</td> <td>8, 9</td> <td>8</td> </tr> <tr> <td>8,9</td> <td>10, 11</td> <td>9</td> </tr> <tr> <td>10</td> <td>12</td> <td>12</td> </tr> <tr> <td>12, 13</td> <td>15</td> <td>16</td> </tr> <tr> <td>14, 15,</td> <td>18</td> <td>28</td> </tr> <tr> <td>16, 17</td> <td>19</td> <td>24</td> </tr> <tr> <td>21</td> <td></td> <td>32</td> </tr> <tr> <td></td> <td>23</td> <td>36</td> </tr> </tbody> </table>	Shell Size			Series 2M801	Series 2M805	Inch Pounds	5, 6, 7	8, 9	8	8,9	10, 11	9	10	12	12	12, 13	15	16	14, 15,	18	28	16, 17	19	24	21		32		23	36	
Shell Size																																
Series 2M801	Series 2M805	Inch Pounds																														
5, 6, 7	8, 9	8																														
8,9	10, 11	9																														
10	12	12																														
12, 13	15	16																														
14, 15,	18	28																														
16, 17	19	24																														
21		32																														
	23	36																														
Unmating force (Series 2M804)	Series 2M804 push/pull connectors <table border="1"> <thead> <tr> <th>Contact Arrangement</th> <th>Inch Pound</th> </tr> </thead> <tbody> <tr> <td>5-3</td> <td>10.6</td> </tr> <tr> <td>6-4</td> <td>10.8</td> </tr> <tr> <td>6-7</td> <td>11.4</td> </tr> <tr> <td>7-10</td> <td>12.0</td> </tr> <tr> <td>8-13</td> <td>12.6</td> </tr> <tr> <td>9-19</td> <td>13.8</td> </tr> <tr> <td>10-26</td> <td>15.2</td> </tr> <tr> <td>12-37</td> <td>17.4</td> </tr> <tr> <td>14-55</td> <td>21.0</td> </tr> </tbody> </table>	Contact Arrangement	Inch Pound	5-3	10.6	6-4	10.8	6-7	11.4	7-10	12.0	8-13	12.6	9-19	13.8	10-26	15.2	12-37	17.4	14-55	21.0											
Contact Arrangement	Inch Pound																															
5-3	10.6																															
6-4	10.8																															
6-7	11.4																															
7-10	12.0																															
8-13	12.6																															
9-19	13.8																															
10-26	15.2																															
12-37	17.4																															
14-55	21.0																															

2M Series Technical Reference

Complete Product Specifications

2M Specs

DESCRIPTION	REQUIREMENT	PROCEDURE			
Insert retention	No impairment of function. Connector shall meet contact resistance, insulation resistance and waterproof sealing.	EIA-365-35			
	Shell Size				
	Series 2M803, 2M804		Series 2M801	Series 2M805	Min. Force in Pounds
	5		5		25
	6		6	8	25
	7		7	9	25
	8		8	10	25
	9		9	11	25
	10		10	12	25
	12		13	15	25
	14		16	18	40
15	17	19	50		
	21	23	80		
Magnetic Permeability	2 μ maximum.	EIA-364-54			

ENVIRONMENTAL

Operating temperature	-65° to +150°C	
Water immersion, mated	No evidence of water penetration into mated connectors. $\geq 100\Omega$ insulation resistance.	MIL-STD-810F Method 512.4 1 meter immersion 1 hour
Water immersion, open face panel mount receptacles with non-removable printed circuit board or solder cup contacts	Connectors with waterblock potting process. 1 X 10 ⁻⁴ cc/second maximum helium leak rate at 1 atmosphere pressure differential following thermal shock conditioning.	EIA-365-02 3 cycles thermal shock -57°C to +71°C 75 min. dwell 5 minute transfer rate
Humidity, cyclic (damp heat, cyclic) (moisture resistance)	No deterioration which will adversely affect the connector. 100 megohms minimum insulation resistance during the final cycle. Following the recovery period, connectors shall meet contact resistance, shell-to-shell resistance and DWV requirements.	EIA-364-31 Condition B Method III 80-98% RH 10 cycles (10 days) +25° C to +65° C Step 7b vibration deleted. 24 hour recovery period.

DESCRIPTION	REQUIREMENT	PROCEDURE
21 day humidity (damp heat, long term)	No deterioration which will adversely affect the connector. Following the drying period, connectors shall meet 100 megohms minimum, contact resistance, shell-to-shell resistance, DWV, mating and unmating requirements.	EIA-364-31 Condition C Method II 90-95% RH 40° C Apply 100 volts DC during test. 4 hours drying time at ambient temperature prior to final measurements.
Thermal shock	No mechanical damage or loosening of parts. Following thermal shock, connector shall meet contact resistance, DWV, insulation resistance and shell-to-shell resistance requirements.	EIA-364-32 Test Condition IV 5 cycles consisting of -65° C 30 minutes, +25° C 5 minutes max., +150° C 30 minutes, +25° C 5 minutes max.
Corrosion (salt mist)	No exposure of base metal. Connectors shall meet DWV and contact resistance requirements following the test.	EIA-364-26 5% salt solution 35° C Unmated connectors Code C: 48 hours Code M: 48 hours Code MT: 500 hours Code NF: 500 hours Code ZN: 500 hours Code ZNU: 500 hours Code UCR: 500 hours
Sand and dust	Mated connectors shall withstand the effects of blowing sand and dust	MIL-STD-810F, Method 510.4
Fungus	Connector materials shall be fungus inert.	MIL-STD-810F, Method 508.5
Fluid immersion	No visible damage from immersion in various fuels and oils. Connector shall meet coupling torque and dielectric withstanding voltage requirements.	EIA-364-10 Unmated connectors
Altitude immersion	No evidence of moisture on connector interface or contacts. Connector shall meet dielectric withstanding voltage.	EIA-364-03

General Information

2M801 Series Micro-Miniature Connector:

Amphenol's 2M801 Series of connectors is ideal for applications where space is limited or a high density interconnect is needed. The series features Plugs with or without anti-decoupling mechanisms and a Dual Start ACME thread that provides full mating in 1 ½ turns. Plugs and Receptacles are provided in two different styles to accommodate the attachment of backshell with rear accessory threads or with integral backshell. The integral backshell allows for use of EMI shielding attachments and/or overmolding. Contact termination styles include Crimp, PC Tail, and Solder cup with others available upon request. Custom and Filter configuration are available, please consult factory for ordering information.

2M801 FEATURES INCLUDE:

- Anti-Vibration Self locking Plugs (-26)
- Dual-Start ACME Thread for 1 ½ Full mating
- Sealed Receptacles:
 - Hermetic (1×10^{-6} cc/second)
 - Epoxy Backfilled (1×10^{-4} cc/second)
- ROHS Compliant Platings available
- Insert Arrangements up to 130 contacts



2M801

2M801 SPECIFICATIONS

Current Rating	See Insert Arrangements (p.7-9)
DWV	See Insert Arrangements (p.7-9)
Insulation Resistance	5000 megohms min.
Operating Temperature	-65°C to +150°C
Shock	300 g's
Random Vibration	37 g's
Shielding Effectiveness	55 dB min. from 100MHz to 1000MHz
Durability	2000 mating cycles

2M801 MATERIALS AND FINISHES

Shells	Aluminum Alloy or Stainless Steel
Contacts	Copper Alloy, gold plated
Insulators	Polyphenylene Sulfide (PPS)
Contact Retention	Beryllium Copper Alloy
Grommet, Interfacial Seal, O'Ring	Fluorosilicone Rubber

SERIES 2M801 MAXIMUM CONNECTOR WEIGHT IN GRAMS

Insert Arr.	Plug	Jam Nut Recept. Crimp	Jam Nut Recept. PCB	Sq. Flange Recept. Crimp	Sq. Flange Recept. PCB	Insert Arr.	Plug	Jam Nut Recept. Crimp	Jam Nut Recept. PCB	Sq. Flange Recept. Crimp	Sq. Flange Recept. PCB
5-3P	4.4	3.4	3.6	2.0	2.2	10-201S	16.7	13.5	14.4	15.0	11.7
5-3S	4.5	3.5	3.7	2.0	2.4	10-202P	14.9	11.7	12.6	13.2	9.9
6-1P	5.6	4.3	4.6	2.7	2.9	10-202S	16.3	13.1	14.0	14.6	11.3
6-1S	5.9	4.6	4.9	3.0	3.2	13-2P	18.9	17.2	17.2	17.2	15.1
6-4P	5.6	4.3	4.6	2.7	2.9	13-2S	20.4	18.7	18.7	18.7	16.6
6-4S	5.8	4.5	4.7	2.8	3.0	13-3P	19.8	18.1	18.1	18.1	16.0
6-7P	5.4	4.1	4.6	2.9	3.4	13-3S	21.4	19.7	19.7	19.7	17.6
6-7S	5.6	4.4	4.7	3.2	3.5	13-7P	20.0	18.3	18.3	18.3	16.2
7-1P	7.8	6.5	7.2	4.5	5.2	13-7S	22.4	20.7	20.7	20.7	18.6
7-1S	8.3	7.0	7.7	5.0	5.7	13-37P	18.4	16.7	16.7	16.7	14.6
7-10P	7.6	6.3	7.7	4.3	5.0	13-37S	19.9	17.6	17.6	17.6	15.5
7-10S	8.0	6.7	7.0	4.7	5.2	13-200P	19.0	17.3	17.3	17.3	15.2
8-2P	8.9	7.7	7.2	5.6	6.8	13-200S	21.1	19.4	19.4	19.4	17.3
8-2S	9.6	8.4	8.7	6.3	7.5	13-201P	19.1	17.4	17.4	17.4	15.3
8-13P	8.3	7.1	9.4	5.0	6.2	13-201S	21.3	19.6	19.6	19.6	17.5
8-13S	8.9	7.6	8.1	5.6	6.5	16-5P	28.5	22.6	24.4	25.4	23.0
8-200P	9.2	8.0	8.5	5.9	7.1	16-5S	31.2	25.3	28.1	28.1	25.7
8-200S	9.8	8.6	9.0	6.5	7.7	16-12P	29.2	23.3	26.1	26.1	23.7
9-4P	10.9	8.7	10.7	7.6	8.6	16-12S	32.5	26.6	29.4	29.4	27.0
9-4S	11.8	10.6	11.6	8.5	9.5	16-55P	26.5	20.6	24.3	24.3	21.9
9-19P	10.1	7.9	9.2	5.8	7.1	16-55S	29.2	23.3	26.1	26.1	23.7
9-19S	10.9	8.7	9.7	6.6	7.6	17-7P	29.8	27.0	29.4	29.4	25.2
9-200P	10.4	9.2	10.2	7.1	8.1	17-7S	33.0	30.2	32.6	32.6	28.4
9-200S	11.4	10.2	11.2	8.1	9.1	17-14P	32.6	29.8	32.2	32.2	28.0
9-201P	9.6	8.4	9.4	6.6	7.6	17-14S	32.3	29.5	31.9	31.9	27.7
9-201S	11.5	10.3	11.3	8.2	9.2	17-85P	28.1	23.2	29.0	29.0	25.3
10-5P	15.8	12.6	13.5	14.1	12.8	17-85S	31.0	26.2	30.6	30.6	26.4
10-5S	17.1	13.9	14.8	15.4	14.1	21-12P	35.0	31.4	34.4	26.4	31.4
10-26P	14.2	11.0	11.9	12.5	8.7	21-12S	39.6	36.0	39.0	31.0	36.0
10-26S	15.3	12.1	12.5	16.7	9.2	21-22P	37.3	33.7	36.7	28.7	33.7
10-200P	15.0	11.8	12.7	13.3	10.0	21-22S	43.6	40.0	43.0	35.0	40.0
10-200S	16.3	13.1	14.0	14.6	11.3	21-130P	32.9	29.3	32.3	24.3	29.3
10-201P	15.3	12.1	13.3	13.6	10.3	21-130S	39.4	35.8	38.8	30.8	35.8

2M801

2M801 Dual-Start ACME Threads

Ordering Guide for 2M801

Series	Shell Style	Service Class	Shell Size-Insert Arrg.	Contact Type	Alternate Position
2M801-0XX	-16	NF	6-7	P	A

SERIES	
2M801-007	Plugs with Integral Backshells
2M801-008	Plugs with Rear Accessory Thread
2M801-009	Receptacle with Integral Backshell
2M801-010	Receptacle with Accessory Thread

SHELL STYLE 2M801-007 2M802-008	
-16	Plug with Anti-Decoupling Spring
-26	Self-Locking Plug with Ratchet Mechanism
SHELL STYLE 2M801-009 2M802-010	
-01	In-Line
-02	Square Flange
-07	Jam Nut

SERVICE CLASS		
		Finish
C		Aluminum/Black Anodize (Non-Conductive)
M		Aluminum/Electroless Nickel
NF		Aluminum/Cadmium with Olive Drab Chromate
MT		Aluminum/Nickel-PTFE (Durmalon)
Z1		Stainless Steel/Passivated
ZN		Aluminum/Zinc-Nickel w/ Olive Drab Chromate
ZNU		Aluminum/Zinc-Nickel with Black Chromate

SHELL SIZE - INSERT ARRANGEMENTS
See Insert Arrangements on Pages 7-9

CONTACTS	
P	Pin Contacts
S	Socket Contacts

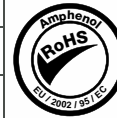

KEYING		
	A°	B°
A	150°	210°
B	75°	210°
C	95°	230°
D	140°	275°
E	75°	275°
F	95°	210°

INSERT ARRANGEMENTS

Insert Arr.	No. of Contacts				
	#23	#20	#20HD	#16	#12
5-3	3				
6-1				1	
6-4	4				
6-6	6				
6-7	7				
6-23			3		
7-1					1
7-10	10				
7-25			5		
8-2				2	
8-13	13				
8-28			8		
8-200	4	2			
9-4				4	
9-19	19				
9-200	4			2	
9-201	8	2			
9-210			10		
10-2					2
10-5				5	
10-26	26				

INSERT ARRANGEMENTS

Insert Arr.	No. of Contacts				
	#23	#20	#20HD	#16	#12
10-200	12				1
10-201	4				2
10-202	8			2	
13-2					2
13-3					3
13-7				7	
13-37	37				
13-200	6				2
13-201	10				2
13-220			20		
16-5					5
16-12				12	
16-55	55				
16-235			35		
17-7					7
17-14				14	
17-85	85				
17-241			41		
21-12					12
21-22				22	
21-130	130				
21-269			69		

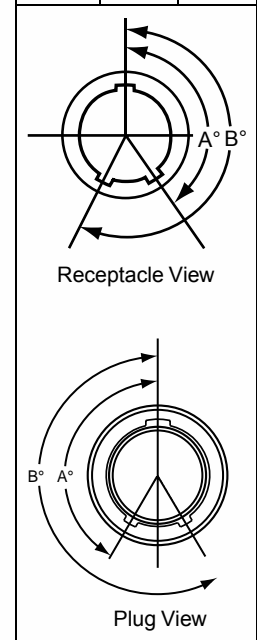

2M801

2M801 Dual-Start ACME Threads Plug

2M801-007 and 2M801-008

2M801

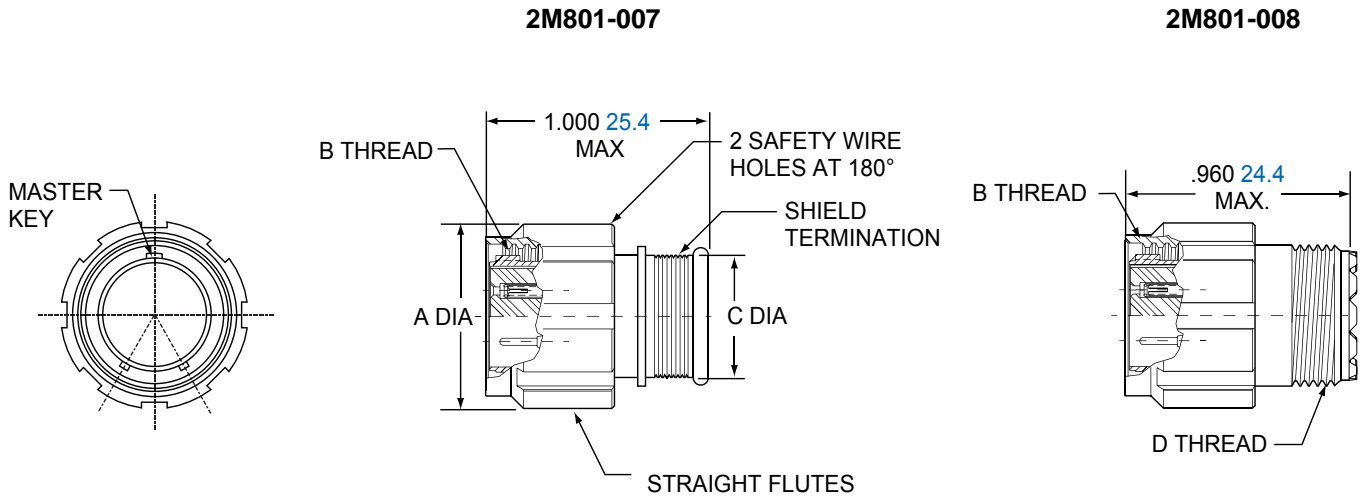

Shell Size	Style 16		Style 26		B Thread	C Dia.		D Thread UNEF-2A
	A Dia.		A Dia.			in.	mm.	
	in.	mm.	in.	mm.				
5	.540	13.72	.640	16.26	.3125-.05P-.1L-2B	.245	6.22	.250-32
6	.600	15.24	.700	17.78	.375-.05P-.1L-2B	.290	7.37	.3125-32
7	.680	17.27	.780	19.81	.4375-.05P-.1L-2B	.390	9.91	.4375-28
8	.750	19.05	.850	21.59	.5000-.05P-.1L-2B	.445	11.30	.5000-28
9	.810	20.57	.910	23.11	.5625-.05P-.1L-2B	.500	12.70	.5625-24
10	.880	22.35	.980	24.89	.6250-.05P-.1L-2B	.560	14.22	.6250-24
13	1.050	26.67	1.150	29.21	.8125-.1P-.2L-2B	.650	16.51	.6875-24
16	1.240	31.50	1.340	34.04	1.000-.1P-.2L-2B	.805	20.45	.9375-20
17	1.300	33.02	1.400	35.56	1.0625-.1P-.2L-2B	.850	21.59	.9375-20
21	1.550	39.37	1.650	41.91	1.3125-.1P-.2L-2B	1.110	28.19	1.1875-18

2M801 Dual-Start ACME Threads Jam Nut

2M801-009-07 and 2M801-010-07

2M801-009-07

2M801-010-07

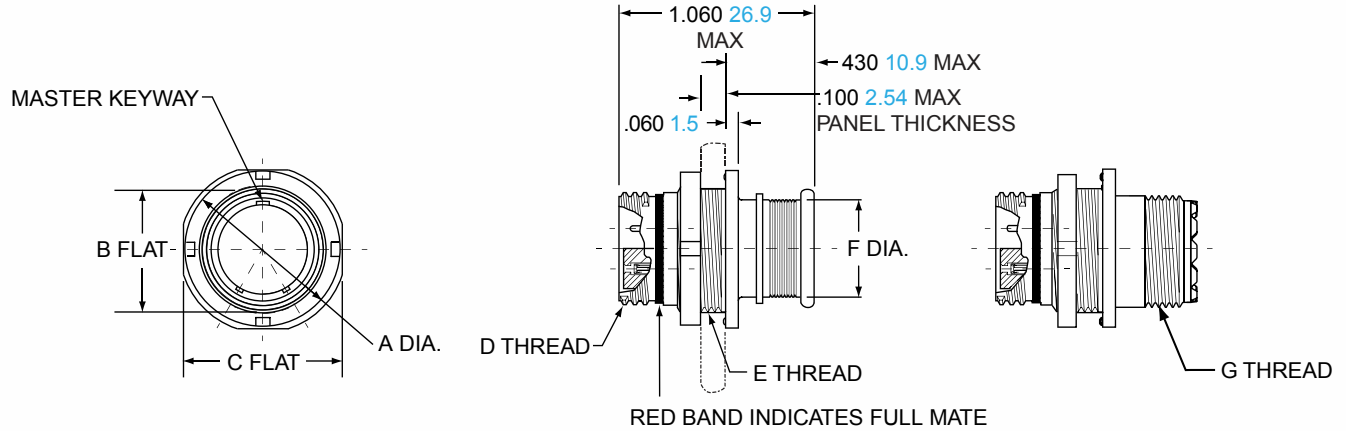

2M801

Shell Size	A Dia.		B Flat		C Flat		D Thread	E Thread	F Dia.		G Thread
	in.	mm.	in.	mm.	in.	mm.			in.	mm.	
5	.575	14.61	.350	8.89	.545	13.84	.3125-.05P-.1L-2A	.375-28 UN-2A	.245	6.22	.250-32 UN-2A
6	.635	16.13	.410	10.41	.595	15.11	.375-.05P-.1L-2A	.4375-28 UN-2A	.290	7.37	.3125-32 UN-2A
7	.755	19.18	.536	13.61	.723	18.36	.4375-.05P-.1L-2A	.5625-32 UN-2A	.390	9.91	.4375-28 UN-2A
8	.755	19.18	.536	13.61	.723	18.36	.5000-.05P-.1L-2A	.5625-32 UN-2A	.445	11.30	.5000-28 UN-2A
9	.830	21.08	.596	15.14	.790	20.07	.5625-.05P-.1L-2A	.625-28 UN-2A	.500	12.70	.5625-24 UN-2A
10	.890	22.61	.658	16.71	.855	21.72	.6250-.05P-.1L-2A	.6875-28 UN-2A	.560	14.22	.6250-24 UN-2A
13	1.078	27.38	.845	21.46	1.044	26.52	.8125-.1P-.2L-2A	.875-28 UN-2A	.650	16.51	.6875-24 UN-2A
16	1.264	32.11	1.022	25.96	1.230	31.24	1.000-.1P-.2L-2A	1.0625-20 UN-2A	.805	20.45	.9375-20 UN-2A
17	1.325	33.66	1.096	27.84	1.290	32.77	1.0625-.1P-.2L-2A	1.125-28 UN-2A	.850	21.59	.9375-20 UN-2A
21	1.625	41.28	1.345	34.16	1.577	40.06	1.3125-.1P-.2L-2A	1.375-28 UN-2A	1.110	28.19	1.1875-18 UN-2A

JAM NUT PANEL CUTOUT

Shell Size	A Flat		B Dia.	
	in. ± .002	mm. ± 0.05	in. ± .002	mm. ± 0.05
5	.356	9.04	.385	9.78
6	.416	10.57	.447	11.35
7	.542	13.77	.572	14.53
8	.542	13.77	.572	14.53
9	.602	15.29	.635	16.13
10	.666	16.62	.697	17.70
13	.851	21.62	.885	22.48
16	1.028	26.11	1.075	27.31
17	1.102	27.99	1.135	28.83
21	1.354	34.39	1.385	35.18

Diagram of the jam nut panel cutout showing dimensions D FLAT and E DIA.

2M801

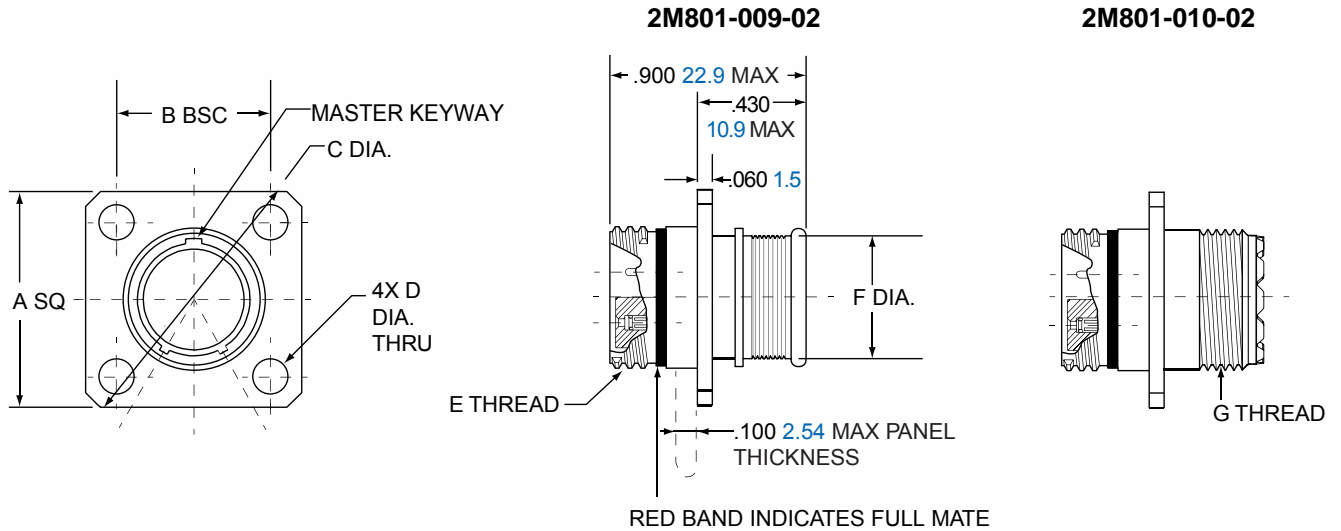

Shell Size	A		B BSC		C Dia.		D Dia.		E Thread	F Dia.		G Thread UN-2A
	in.	mm.	in.	mm.	in.	mm.	in. ± .003	mm. ± .08		in.	mm.	
5	.530	13.46	.363	9.22	.680	17.27	.093	2.36	.3125-.05P-1L-2A	.245	6.22	.250-32
6	.590	14.99	.423	10.74	.750	19.05	.093	2.36	.375-.05P-1L-2A	.290	7.37	.3125-32
7	.650	16.51	.483	12.27	.850	21.59	.093	2.36	.4375-.05P-1L-2A	.390	9.91	.4375-28
8	.712	18.08	.545	13.84	.938	23.83	.093	2.36	.5000-.05P-1L-2A	.445	11.30	.5000-28
9	.850	21.59	.607	15.42	1.125	28.58	.128	3.25	.5625-.05P-1L-2A	.500	12.70	.5625-24
10	.890	22.61	.670	17.02	1.188	30.18	.128	3.25	.6250-.05P-1L-2A	.560	14.22	.6250-24
13	1.030	26.16	.812	20.62	1.375	34.93	.128	3.25	.8125-.1P-.2L-2A	.650	16.51	.6875-24
16	1.219	30.96	.981	24.92	1.625	41.28	.128	3.25	1.000-.1P-.2L-2A	.805	20.45	.9375-20
17	1.280	32.51	1.060	26.92	1.700	43.18	.128	3.25	1.0625-.1P-.2L-2A	.850	21.59	.9375-20
21	1.430	36.32	1.205	30.61	1.938	49.23	.128	3.25	1.3125-.1P-.2L-2A	1.110	28.19	1.1875-18

PANEL CUTOUT

Shell Size	A Dia.		B Dia.		C Dia.	
	in.	mm.	in.	mm.	in.	mm.
5	.330	8.38	.363	9.22	.093	2.36
6	.390	9.91	.423	10.74	.093	2.36
7	.450	11.43	.483	12.27	.093	2.36
8	.510	12.95	.545	13.84	.093	2.36
9	.575	14.61	.607	15.42	.128	3.25
10	.640	16.26	.670	17.02	.128	3.25
13	.825	20.96	.812	20.65	.128	3.25
16	1.015	25.78	.981	24.92	.128	3.25
17	1.075	27.31	1.060	26.92	.128	3.25
21	1.325	33.66	1.205	30.61	.128	3.25

2M801 Dual-Start ACME Threads In-Line

2M801-009-01 and 2M801-010-01

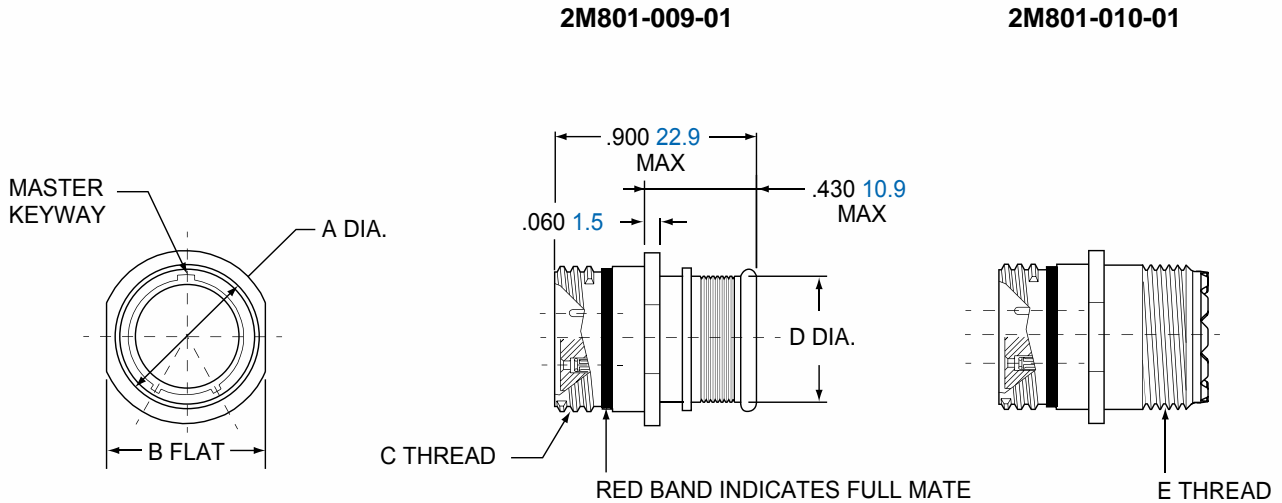

Shell Size	A Dia.		B Flat		C Thread	D Dia.		E Thread UNEF-2A
	in.	mm.	in.	mm.		in.	mm.	
5	.355	9.02	.325	8.13	.3125-.05P-.1L-2A	.245	6.22	.250-32
6	.415	10.54	.385	9.78	.375-.05P-.1L-2A	.290	7.37	.3125-32
7	.480	12.19	.445	11.30	.4375-.05P-.1L-2A	.390	9.91	.4375-28
8	.540	13.72	.510	12.95	.5000-.05P-.1L-2A	.445	11.30	.5000-28
9	.605	15.37	.575	14.61	.5625-.05P-.1L-2A	.500	12.70	.5625-24
10	.665	16.89	.635	16.13	.6250-.05P-.1L-2A	.560	14.22	.6250-24
13	.855	21.72	.825	20.96	.8125-.1P-.2L-2A	.650	16.51	.6875-24
16	1.040	26.42	1.010	25.65	1.000-.1P-.2L-2A	.805	20.44	.9375-20
17	1.110	28.19	1.070	27.18	1.0625-.1P-.2L-2A	.850	21.59	.9375-20
21	1.405	35.69	1.385	35.18	1.3125-.1P-.2L-2A	1.110	28.19	1.1875-18

2M801 Series of PC Board Receptacles:

2M801 Series of PC Board Receptacles are intended for use of terminating the connector directly to a Circuit Board or Flex assembly. These connectors however can be supplied with Soldercup termination for direct wire attachment.

2M801

2M801 FEATURES INCLUDE:

- Low profile shells for minimum box protrusion
- Shell Standoff's for PC Board washout
- Non-removable PC and/or Soldercup contacts
- Environmental Sealing



Series	Shell Style	Service Class	Shell Size-Insert Arrg.	Contact Type	Alternate Position
2M801-0XX	-02	MF	6-7	P	A

SERIES	
2M801-011	Receptacle for Solder Cup or PCB Termination with Epoxy Potting
2M801-033	Receptacle with Solder Cup or PCB Termination with Special Sealing for Open Face (unmated) Water Immersion Requirements. 100% Leak Tested. To maintain a helium leak rate of 1-10 ⁻⁴ cc/sec. pressure differential from -40°C to 70° C.

SHELL STYLE	
-02	Square Flange
-07	Jam Nut

SHELL SIZE - INSERT ARRANGEMENTS
See Insert Arrangements on Pages 7-9

SERVICE CLASS		
		Finish
C		Aluminum/Black Anodize (Non-Conductive)
M		Aluminum/Electroless Nickel
NF		Aluminum/Cadmium with Olive Drab Chromate
MT		Aluminum/Nickel-PTFE (Durmalon)
Z1		Stainless Steel/Passivated
ZN		Aluminum/Zinc-Nickel w/Olive Drab Chromate
ZNU		Aluminum/Zinc-Nickel with Black Chromate

KEYING		
	A°	B°
(Normal) A	150°	210°
B	75°	210°
C	95°	230°
D	140°	275°
E	75°	275°
F	95°	210°

Receptacle View

CONTACTS	
P	Pin Contacts PCB
S	Socket Contacts PCB
E	Pin, Solder Cup
F	Socket, Solder Cup



2M801 Dual-Start ACME Threads

Jam Nut and Square Flange 2M801-011 and 2M801-033

2M801-011-07
2M801-033-07

2M801-011-02
2M801-033-02

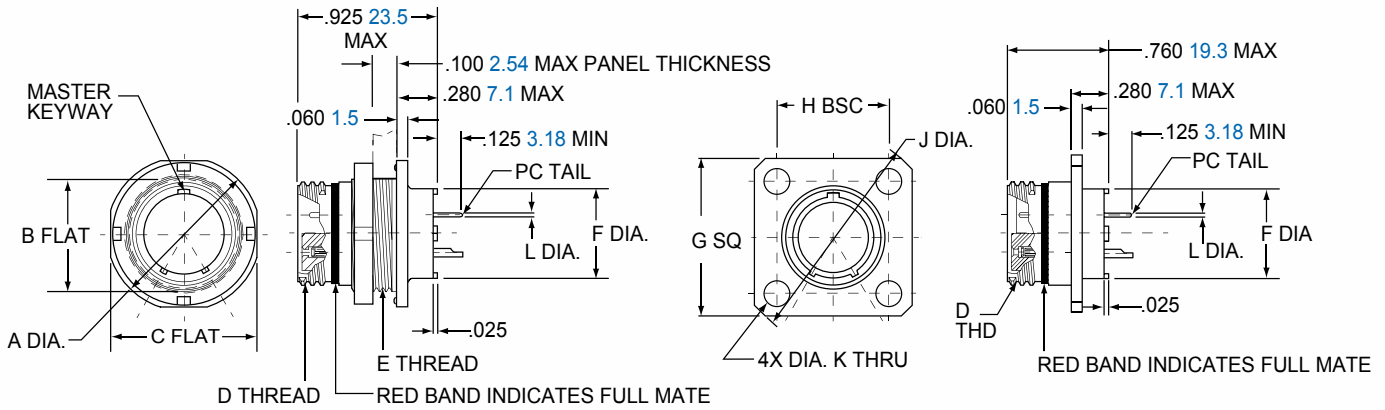

2M801

Shell Size	A Dia.		B Flat		C Flat		D Thread	E Thread	F Dia.		G Sq.		H BSC		J Dia.		K Dia.		L Dia. Tail Dia.
	in.	mm.	in.	mm.	in.	mm.			in.	mm.	in.	mm.	in.	mm.	in.	mm.	in.	mm.	
5	.575	14.61	.350	8.89	.545	13.84	.3125-.05P-.1L-2A	.375-28	.244	6.20	.530	13.46	.363	9.22	.680	17.27	.093	2.36	#23 .018/.022 0.46/0.56
6	.635	16.13	.410	10.41	.595	15.11	.375-.05P-.1L-2A	.4375-28	.330	8.38	.590	14.99	.423	10.74	.750	19.05	.093	2.36	
7	.755	19.18	.536	13.61	.723	18.36	.4375-.05P-.1L-2A	.5625-32	.432	10.97	.650	16.51	.483	12.27	.850	21.59	.093	2.36	
8	.755	19.18	.536	13.61	.723	18.36	.5000-.05P-.1L-2A	.5625-32	.493	12.52	.712	18.08	.545	13.84	.938	23.83	.128	3.25	#16 .060/.064 1.52/1.63
9	.830	21.08	.596	15.14	.790	20.07	.5625-.05P-.1L-2A	.6250-28	.551	14.00	.850	21.56	.607	15.42	1.125	28.58	.128	3.25	
10	.890	22.61	.658	16.71	.855	21.72	.6250-.05P-.1L-2A	.6875-28	.620	15.75	.890	22.61	.670	17.02	1.188	30.18	.128	3.25	
13	1.078	27.38	.845	21.46	1.044	26.52	.8125-.1P-.2L-2A	.875-28	.703	17.86	1.030	26.16	.812	20.62	1.375	34.93	.128	3.25	
16	1.264	32.11	1.022	25.96	1.230	31.24	1.000-.1P-.2L-2A	1.0625-20	.863	21.92	1.219	30.96	.981	24.92	1.625	41.28	.128	3.25	#12 .092/.096 2.34/2.44
17	1.325	33.66	1.096	27.84	1.290	32.77	1.0625-.1P-.2L-2A	1.125-28	.912	23.16	1.280	32.51	1.060	26.92	1.700	43.18	.128	3.25	
21	1.625	41.28	1.345	34.16	1.577	40.06	1.3125-.1P-.2L-2A	1.375-28	1.170	29.72	1.565	39.75	1.322	33.58	2.100	53.34	.128	3.25	

PANEL CUTOUT

Shell Size	A Dia.		B Dia.		C Dia.		D Flat		E Dia.	
	in.	mm.	in.	mm.	in.	mm.	in.	mm.	in.	mm.
	± .002		± 0.05		± .002		± 0.05		± .002	
5	.330	8.38	.363	9.22	.093	2.36	.356	9.04	.385	9.78
6	.390	9.91	.423	10.74	.093	2.36	.416	10.57	.447	11.35
7	.450	11.43	.483	12.27	.093	2.36	.542	13.77	.572	14.53
8	.510	12.95	.545	13.84	.093	2.36	.542	13.77	.572	14.53
9	.575	14.61	.607	15.42	.128	3.25	.602	15.29	.635	16.13
10	.640	16.26	.670	17.02	.128	3.25	.666	16.92	.697	17.70
13	.825	20.96	.812	20.65	.128	3.25	.851	21.62	.885	22.48
16	1.015	25.78	.981	24.92	.128	3.25	1.028	26.11	1.075	27.31
17	1.075	27.31	1.060	26.92	.128	3.25	1.102	27.99	1.135	28.83
21	1.330	33.78	1.322	33.58	.128	3.25	1.354	34.39	1.385	35.18

2M801 Series of Hermetic Receptacles:

2M801 Series of Hermetic Receptacles provide superior sealing of 1×10^{-6} cc/second helium leak rate and are 100% tested prior to shipping. This superior sealing is accomplished through the use of glass insulator fused to stainless steel shells and iron alloy contacts.

2M801 FEATURES INCLUDE:

- Low profile shells for minimum box protrusion
- Shell Standoff's for PC Board washout
- Non-removable PC and/or Soldercup contacts
- Hermetic Sealing

2M801

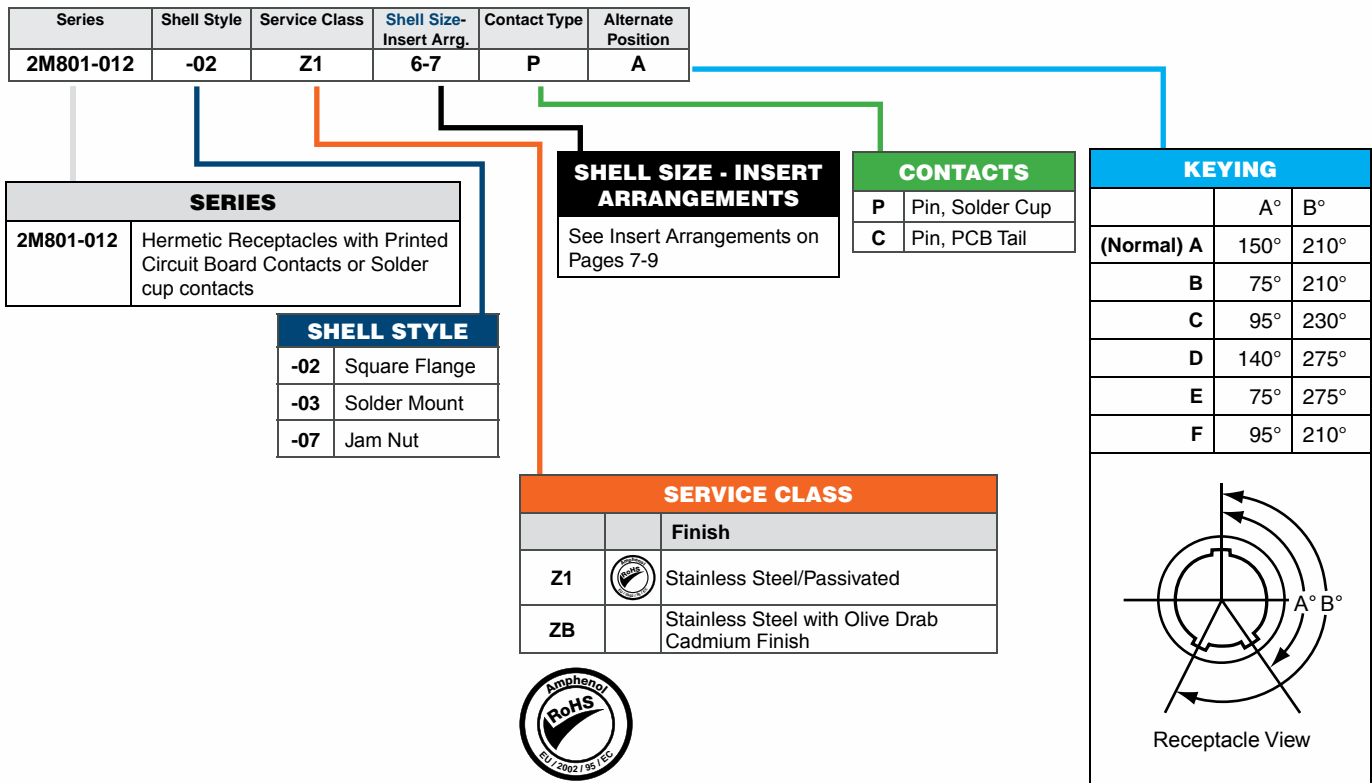

2M801 Dual-Start ACME Threads

Hermetic Jam Nut Connector 2M801-012-07

2M801-012-07

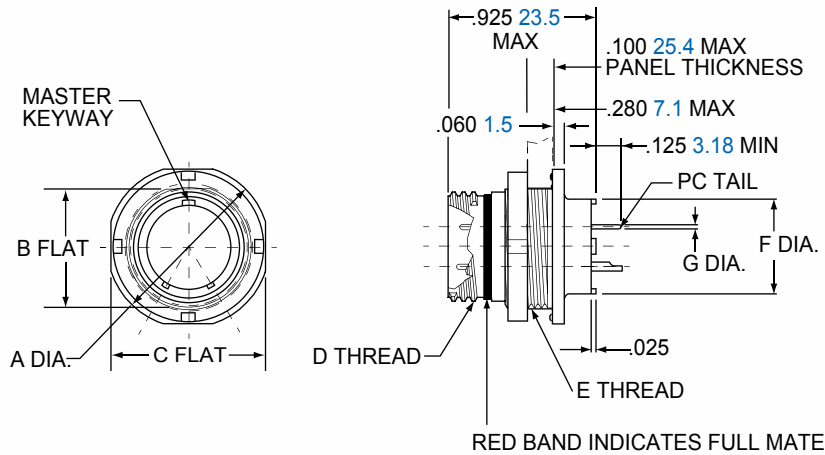

2M801

Shell Size	A Dia.		B Flat		C Flat		D Thread	E Thread UN-2A	F Dia.		G Dia. Tail Dia.
	in.	mm.	in.	mm.	in.	mm.			in.	mm.	
5	.575	14.61	.350	8.89	.545	13.84	.3125-.05P-.1L-2A	.375-28	.244	6.20	#23 .018/.022
6	.635	16.13	.410	10.41	.595	15.11	.375-.05P-.1L-2A	.4375-28	.330	8.38	0.46/0.56 #20
7	.755	19.18	.536	13.61	.723	18.36	.4375-.05P-.1L-2A	.5625-32	.432	10.97	.024/.028 0.61/0.71 #16
8	.755	19.18	.536	13.61	.723	18.36	.5000-.05P-.1L-2A	.5625-32	.493	12.52	0.61/0.71 #16
9	.830	21.08	.596	15.14	.790	20.07	.5625-.05P-.1L-2A	.6250-28	.551	14.00	.060/.064 1.52/1.63 #12
10	.890	22.61	.658	16.71	.855	21.72	.6250-.05P-.1L-2A	.6875-28	.620	15.75	1.52/1.63 #12
13	1.078	27.38	.845	21.46	1.044	26.52	.8125-.1P-.2L-2A	.875-28	.703	17.86	.092/.096 2.34/2.44
16	1.264	32.11	1.022	25.96	1.230	31.24	1.000-.1P-.2L-2A	1.0625-20	.863	21.92	
17	1.325	33.66	1.096	27.84	1.290	32.77	1.0625-.1P-.2L-2A	1.125-28	.912	23.16	
21	1.625	41.28	1.345	34.16	1.577	40.06	1.3125-.1P-.2L-2A	1.375-28	1.170	29.72	

PANEL CUTOUT

Shell Size	A Flat		B Dia.	
	in. ±.002	mm. ± 0.05	in. ±.002	mm. ± 0.05
5	.356	9.04	.385	9.78
6	.416	10.57	.447	11.35
7	.542	13.77	.572	14.53
8	.542	13.77	.572	14.53
9	.602	15.29	.635	16.13
10	.666	16.92	.697	17.70
13	.851	21.62	.885	22.48
16	1.028	26.11	1.075	27.31
17	1.102	27.99	1.135	28.83
21	1.354	34.39	1.385	35.18

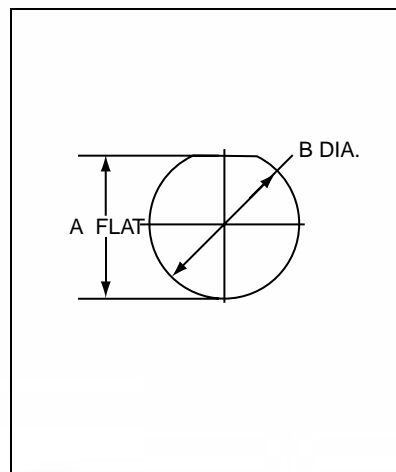

2M801 Dual-Start ACME Threads

Hermetic Square Flange Connector 2M801-012-02

2M801

2M801-012-02

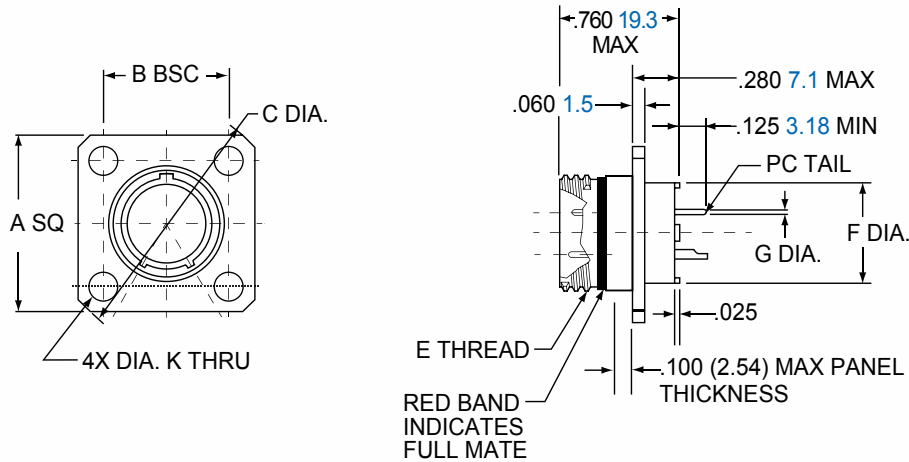

Shell Size	A SQ.		B BSC		C Dia.		D Dia.		E Thread	F Dia.		G Dia. Tail Dia.
	in.	mm.	in.	mm.	in.	mm.	in.	mm. ± 0.08		in.	mm.	
5	.530	13.46	.363	9.22	.680	17.27	.093	2.36	.3125-.05P-.1L-2A	.244	6.20	#23 .018/.022
6	.590	14.99	.423	10.74	.750	19.05	.093	2.36	.375-.05P-.1L-2A	.330	8.38	0.46/0.56
7	.650	16.51	.483	12.27	.850	21.59	.093	2.36	.4375-.05P-.1L-2A	.432	10.97	#20 .024/.028
8	.712	18.08	.545	13.84	.938	23.83	.093	2.36	.5000-.05P-.1L-2A	.493	12.52	0.60/0.71
9	.850	21.56	.607	15.42	1.125	28.58	.128	3.25	.5625-.05P-.1L-2A	.551	14.00	#16 .060/.064
10	.890	22.61	.670	17.02	1.188	30.18	.128	3.25	.6250-.05P-.1L-2A	.620	15.75	1.52/1.63
13	1.030	26.16	.812	20.62	1.375	34.93	.128	3.25	.8125-.1P-.2L-2A	.703	17.86	#12 .092/.096
16	1.219	31.96	.981	24.92	1.625	41.28	.128	3.25	1.000-.1P-.2L-2A	.863	21.92	2.34/2.44
17	1.280	32.51	1.060	26.92	1.700	43.18	.128	3.25	1.0625-.1P-.2L-2A	.912	23.16	
21	1.430	36.32	1.205	30.61	1.938	49.23	.128	3.25	1.3125-.1P-.2L-2A	1.170	29.72	

PANEL CUTOUT

Shell Size	A Dia.		B Dia.		C Dia.	
	in.	mm.	in.	mm.	in.	mm.
5	.330	8.38	.363	9.22	.093	2.36
6	.390	9.91	.423	10.74	.093	2.36
7	.450	11.43	.483	12.27	.093	2.36
8	.510	12.95	.545	13.84	.093	2.36
9	.575	14.61	.607	15.42	.128	3.25
10	.640	16.26	.670	17.02	.128	3.25
13	.825	20.96	.812	20.65	.128	3.25
16	1.015	25.78	.981	24.92	.128	3.25
17	1.075	27.31	1.060	26.92	.128	3.25
21	1.325	33.66	1.205	30.61	.128	3.25

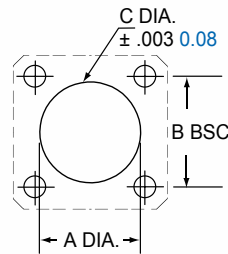

2M801 Dual-Start ACME Threads

Hermetic Solder Mount Connector 2M801-012-03

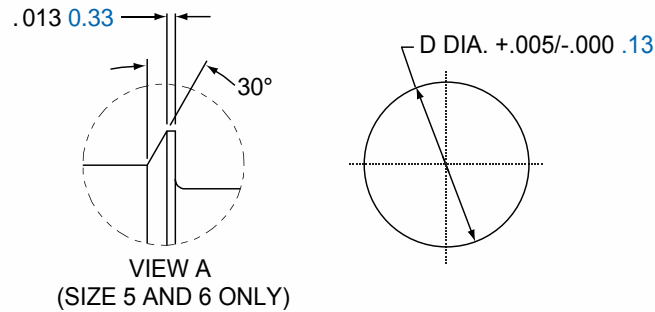
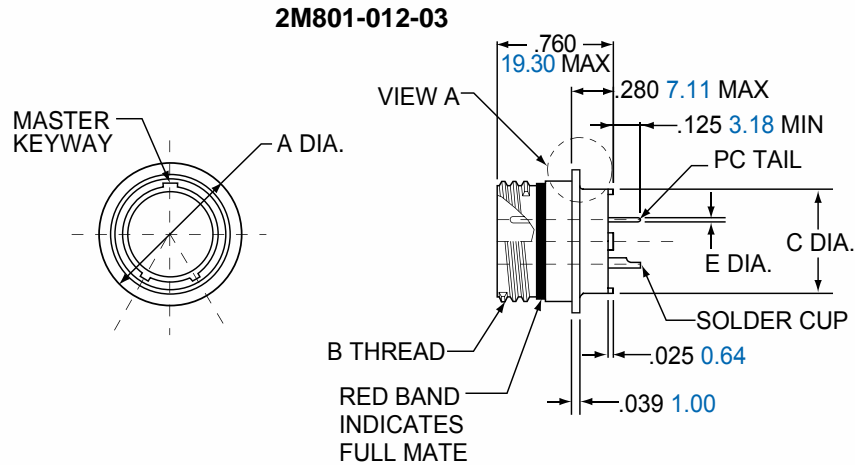

Shell Size	A Dia		B Thread	C Dia.		D Dia. Panel Cutout		G. PC Tail Dia.
	in.	mm.		in.	mm.	in.	mm.	
5	.395	10.03	.3125-.05P-.1L-2A	.244	6.20	.319	8.10	#23
6	.455	11.56	.375-.05P-.1L-2A	.330	8.38	.379	9.55	.018/.022 0.46/0.56
7	.520	13.21	.4375-.05P-.1L-2A	.432	11.97	.438	11.13	#20
8	.580	14.73	.5000-.05P-.1L-2A	.493	12.52	.438	11.13	.024/.028 0.61/0.71
9	.645	16.38	.5625-.05P-.1L-2A	.551	14.00	.563	14.30	#16
10	.705	18.01	.6250-.05P-.1L-2A	.620	15.75	.438	11.13	.060/.064
13	.895	22.73	.8125-.1P-.2L-2A	.703	17.86	.814	20.68	1.52/1.63
16	1.080	27.43	1.000-.1P-.2L-2A	.863	21.92	1.007	25.58	#12
17	1.145	29.08	1.0625-.1P-.2L-2A	.912	23.16	1.067	27.10	.092/.096 2.34/2.44
21	1.395	35.43	1.3125-.1P-.2L-2A	1.170	29.72	1.320	33.53	

2M801

Protection Caps:

Protection Caps are used to protect unmated connectors from damage.

2M801 FEATURES INCLUDE:

- Aluminum or Stainless Steel Bodies
- Rubber Gasket's for Environmental Sealing
- Stainless Steel Fittings
- Variety of attachments

2M801

Series	Service Class	Attachment Type	Shell Size	Attachment Code	Attachment Length in Inches
2M667-21X	-NF	-S	5	04	-5

Omit for attachment Type N (No Attachment)
Example "-5" equals 5 inch length

SERIES		ATTACHMENT TYPE		SHELL SIZE	ATTACHMENT CODE	
2M667-217	Protection Cap for 2M801 Plugs	-G	Nylon Rope	5	Omit for attachment Types N (No Attachment) and Slip Knot	
2M667-218	Protection Cap for 2M801 Receptacles	-H	Stainless Steel Wire Rope, Teflon® Jacket	6	Small Ring	01 –.126 (3.20) I.D.
		-N	No Attachment	7		02 –.145 (3.68) I.D.
		-S	Stainless Steel Sash Chain	8		04 –.188 (4.78) I.D.
		-SK	Nylon Rope With Slip Knot	9		06 –.197 (5.00) I.D.
		-T	Stainless Steel Wire Rope, No Jacket	10		14 –.385 (9.78) I.D.
		-U	Stainless Steel Wire Rope, Polyurethane Jacket	13		15 –.445 (11.30) I.D.
				16	Large Ring	16 –.570 (14.48) I.D.
				17		17 –.635 (16.13) I.D.
				21		18 –.695 (17.65) I.D.
						19 –.885 (22.48) I.D.
						20 –1.070 (27.17) I.D.
						21 –1.135 (28.83) I.D.
						22 –1.210 (30.73) I.D.
						23 –1.275 (32.39) I.D.
					24 –1.375 (34.94) I.D.	
					Split Ring	50 –.420 (10.67) I.D.
						52 –.480 (12.19) I.D.
						54 –.635 (16.13) I.D.
						56 –.745 (18.92) I.D.
						58 –.885 (22.48) I.D.
						60 –1.010 (25.65) I.D.
					64 –1.125 (28.58) I.D.	
					68 –1.345 (34.16) I.D.	

SERVICE CLASS	
Finish	
C	Aluminum/Black Anodize (Non-Conductive)
M	Aluminum/Electroless Nickel
NF	Aluminum/Cadmium with Olive Drab Chromate
MT	Aluminum/Nickel-PTFE (Durmalon)
Z1	Stainless Steel/Passivated
ZN	Aluminum/Zinc-Nickel w/Olive Drab Chromate
ZNU	Aluminum/Zinc-Nickel with Black Chromate



2M801 Dual-Start ACME Threads

Metal Protective Cap 2M667-217 and 2M667-218

2M667-217 (Plug)

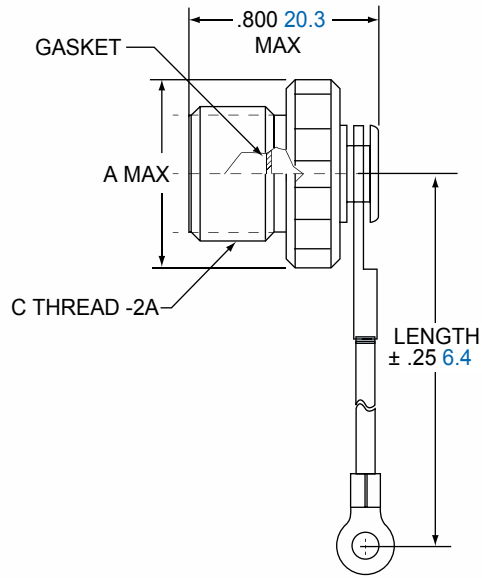

2M667-218 (Receptacle)

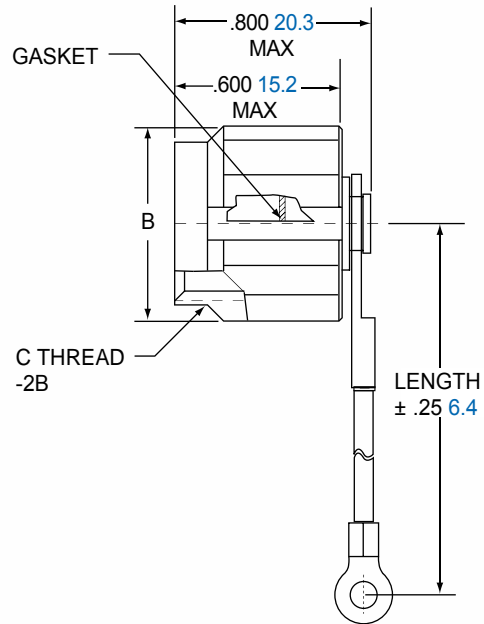

2M801

Shell Size	A Max.		B Max.		C
	in.	mm.	in.	mm.	
5	.465	11.81	.488	12.40	.3125-.05P-1L
6	.525	13.34	.555	14.10	.375-.05P-1L
7	.590	14.99	.615	15.62	.4375-.05P-1L
8	.653	16.59	.675	17.15	.5000-.05-.1L
9	.715	18.16	.840	21.34	.5625-.05P-.1L
10	.778	19.76	.905	22.95	.6250-.05P-1L
13	.965	24.51	.995	25.27	.8125-.1P-.2L
16	1.150	29.21	1.261	32.03	1.000-.1P-.2L
17	1.215	30.86	1.321	33.55	1.0625-.1P-.2L
21	1.477	37.52	1.570	39.88	1.3125-.1P-.2L

MATERIALS

Cover	Aluminum alloy or stainless steel
Gasket	Silicone rubber
Wire, Hardware	Stainless steel, passivated

LANYARD OPTIONS

	Nylon Rope	-55° to +100°C., black, flexible, good abrasion resistance, good resistance to fuels, .120" 3mm diameter
	Polyurethane Coated Wire Rope	Black polyurethane over stainless steel rope, very flexible, excellent abrasion resistance, excellent resistance to fuels, .080" 2mm diameter
	Teflon® Jacketed Wire Rope	Translucent FEP jacket over stainless steel, -55° to +200°C., fair flexibility, good abrasion resistance, .100" diameter
	Sash Chain	Stainless steel, #8 Chain
	Slip Knot (SK) for attaching Covers to Cables	55° to +100°C., black, flexible, good abrasion resistance, good resistance to fuels, .120" 3mm diameter. Length includes .5" 13mm diameter loop.

2M803 Series Micro-Miniature Connectors:

Amphenol's 2M803 Series of connectors is ideal for applications where space is limited or a high density interconnect is needed. The series features bayonet connectors with 1/4 turn full mate coupling. Plugs and Receptacles are provided in two different styles to accommodate the attachment of backshell with rear accessory threads or with integral backshell. The integral backshell allows for use of EMI shielding attachments and/or overmolding. Contact termination styles include Crimp, PC Tail, and Solder cup with others available upon request. Custom and Filter configuration are available, please consult factory for ordering information.

2M803 FEATURES INCLUDES:

- Bayonet Coupling for 1/4 Full mating
- Sealed Receptacles:
 - Hermetic (1×10^{-6} cc/second)
 - Epoxy Backfilled (1×10^{-4} cc/second)
- ROHS Compliant Platings available
- Insert Arrangements up to 55 contacts



2M803 SPECIFICATIONS

Current Rating	See Insert Arrangements (p.8-10)
DWV	See Insert Arrangements (p.8-10)
Insulation Resistance	5000 megohms min.
Operating Temperature	-65°C to +150°C
Shock	300 g's
Random Vibration	37 g's
Shielding Effectiveness	40 dB min. from 100MHz to 1000MHz
Durability	Aluminum: 250 mating cycles Stainless Steel: 2000 mating cycles

2M803 MATERIALS AND FINISHES

Shells	Aluminum Alloy or Stainless Steel
Contacts	Copper Alloy, gold plated
Insulators	Polyphenylene Sulfide (PPS)
Contact Retention	Beryllium Copper Alloy
Grommet, Interfacial Seal, O'Ring	Fluorosilicone Rubber

2M803 1/4 Turn Bayonet Coupling

Weights

SERIES 2M803 MAXIMUM CONNECTOR WEIGHT IN GRAMS

Insert Arrangements	Cable Plug	Jam Nut Receptacle Crimp	Jam Nut Receptacle PCB	Flange Receptacle Crimp	Flange Receptacle PCB
5-3P	3.6	3.6	3.9	2.9	3.3
5-3S	3.7	3.7	4.0	3.1	3.4
6-1P	4.4	4.4	4.6	3.1	3.5
6-1S	4.5	4.5	4.7	3.2	3.6
6-4P	4.7	3.7	4.1	3.1	3.6
6-4S	4.7	4.0	4.2	3.2	3.7
6-7P	5.1	4.8	5.3	3.3	4.4
6-7S	5.1	5.1	5.5	3.6	4.4
7-1P	5.7	5.9	5.8	4.4	4.7
7-1S	5.9	6.2	5.9	4.7	5.1
7-10P	6.9	7.4	8.1	5.0	6.5
7-10S	7.4	7.8	8.4	5.4	6.6
8-2P	8.6	8.9	9.9	6.6	8.6
8-2S	9.4	9.7	10.7	7.4	9.4
8-13P	7.9	8.3	9.2	5.9	7.9
8-13S	8.7	8.9	9.7	6.6	8.1
8-200P	8.9	9.2	10.2	6.9	8.9
8-200S	9.6	9.9	10.9	6.9	9.6
9-4P	9.2	9.6	10.6	6.6	9.2
9-4S	9.6	9.9	10.9	6.9	9.6
9-19P	9.2	9.1	10.6	7.0	9.9
9-19S	10.2	10.1	11.2	8.1	10.2
9-200P	9.1	9.5	10.5	7.2	9.1
9-200S	10.2	10.6	11.6	8.3	10.2
9-201P	9.2	9.6	10.6	7.3	10.3
9-201S	9.8	10.1	11.7	8.4	10.3
10-5P	13.4	14.1	15.0	10.6	13.9
10-5S	14.9	15.5	17.5	12.0	15.3
10-26P	11.7	12.3	14.3	8.8	12.8
10-26S	13.4	13.6	15.1	10.1	13.1
10-200P	12.5	13.2	15.2	9.7	13.0
10-200S	14.0	14.6	16.6	11.1	14.4
10-201P	12.9	13.5	15.5	10.0	13.3
10-201S	14.4	15.1	17.1	11.6	14.9
10-202P	12.4	13.1	15.1	9.6	11.8
10-202S	14.0	14.6	16.6	11.1	14.4
12-2P	15.5	16.4	19.1	11.4	16.9
12-2S	17.2	18.0	20.8	13.1	18.6
12-3P	16.5	17.4	20.1	12.4	17.9
12-3S	18.3	19.1	21.9	14.2	19.7
12-7P	16.7	17.6	20.4	12.7	18.2
12-7S	19.4	20.2	23.0	15.3	20.8
12-37P	15.0	15.8	18.6	10.9	16.4
12-37S	16.6	17.5	19.6	12.4	16.7
12-200P	15.6	16.5	19.3	11.6	17.1
12-200S	17.9	18.8	21.6	13.9	19.4
12-201P	15.7	16.6	19.4	11.7	17.2
12-201S	18.2	19.0	21.8	14.1	19.6
14-5P	22.2	23.5	27.7	17.3	25.5
14-5S	24.8	26.1	29.3	19.8	25.1
14-55P	19.6	20.9	25.1	14.6	22.9
14-55S	22.6	23.9	27.1	14.6	23.9

2M803

Series	Shell Style	Service Class	Shell Size- Insert Arrg.	Contact Type	Alternate Position
2M803-00X	-06	NF	6-7	P	N

SERIES	
2M803-001	Plug with Crimp Contact, Integral Back-shell for Direct Attachment of Cable Shield and Overmold
2M803-002	Plug with Crimp Contact, Rear-Accessory Thread
2M803-003	Receptacle with Integral Backshell for Direct Attachment of Cable Shield and Overmold
2M803-004	Receptacle with Rear Accessory Thread

SHELL STYLE 2M803-001, 2M803-002	
-06	Plug
SHELL STYLE 2M803-003, 2M803-004	
-07	Jam Nut
-02	Flange Mount
-01	In-Line

SHELL SIZE - INSERT ARRANGEMENTS
See Insert Arrangements on Pages 7-9



CONTACTS	
P	Pin Contacts
S	Socket Contacts

SERVICE CLASS		
	Finish	
C		Aluminum/Black Anodize (Non-Conductive)
M		Aluminum/Electroless Nickel
NF		Aluminum/Cadmium with Olive Drab Chromate
MT		Aluminum/Nickel-PTFE (Durmalon)
Z1		Stainless Steel/Passivated
ZN		Aluminum/Zinc-Nickel w/Olive Drab Chromate
ZNU		Aluminum/Zinc-Nickel with Black Chromate

KEYING		
Key Position	Key Rotation	
	A	B
N	150°	210°
X	75°	210°
Y	95°	230°
Z	140°	275°

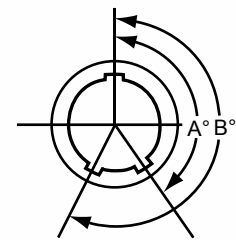

Receptacle View

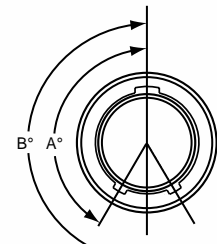

Plug View

INSERT ARRANGEMENTS

Insert Arr.	No. of Contacts				
	#23	#20	#20HD	#16	#12
5-3	3				
6-1				1	
6-4	4				
6-6	6				
6-7	7				
6-23			3		
7-1					1
7-10	10				
7-25			5		
8-2				2	
8-28			8		
8-13	13				
8-200	4	2			
9-4				4	
9-19	19				
9-200	4			2	
9-201	8	2			
9-210			10		
10-2					2

INSERT ARRANGEMENTS

Insert Arr.	No. of Contacts				
	#23	#20	#20HD	#16	#12
10-5				5	
10-26	26				
10-200	12				1
10-201	4				2
10-202	8			2	
12-2					2
12-3					3
12-7				7	
12-37	37				
12-200	6				2
12-201	10				2
12-220			20		
14-5					5
14-12				12	
14-55	55				
14-235			35		

2M803 1/4 Turn Bayonet Coupling Plug

2M803-001-06 and 2M803-002-06

2M803-001-06

2M803-002-06

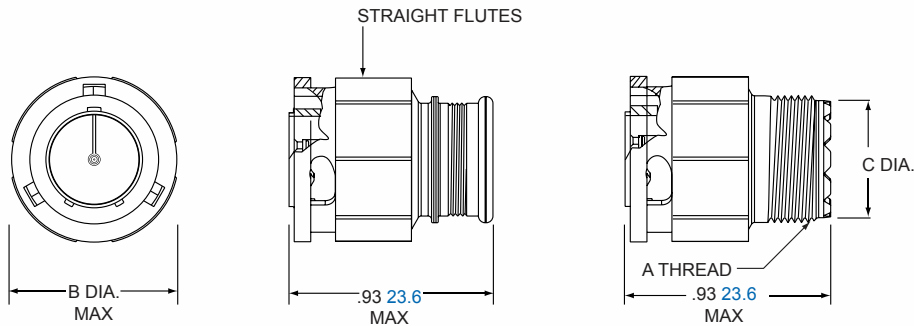

2M803

Shell Size	A Thread	B Dia. Max		C Dia.	
		in.	mm.	in.	mm.
5	.2500-32 UNEF-2A	.500	12.70	.245	6.22
6	.3125-32 UNEF-2A	.565	14.35	.290	7.37
7	.4375-28 UNEF-2A	.650	16.51	.390	9.91
8	.5000-28 UNEF-2A	.750	19.05	.440	11.18
9	.5625-24 UNEF-2A	.790	20.07	.500	12.70
10	.6250-24 UNEF-2A	.875	22.23	.562	14.27
12	.6875-24 UNEF-2A	.944	23.98	.650	16.51
14	.9375-20 UNEF-2A	1.095	27.81	.805	20.45

2M803 1/4 Turn Bayonet Coupling Jam Nut

2M803-003-07 and 2M803-004-07

2M803

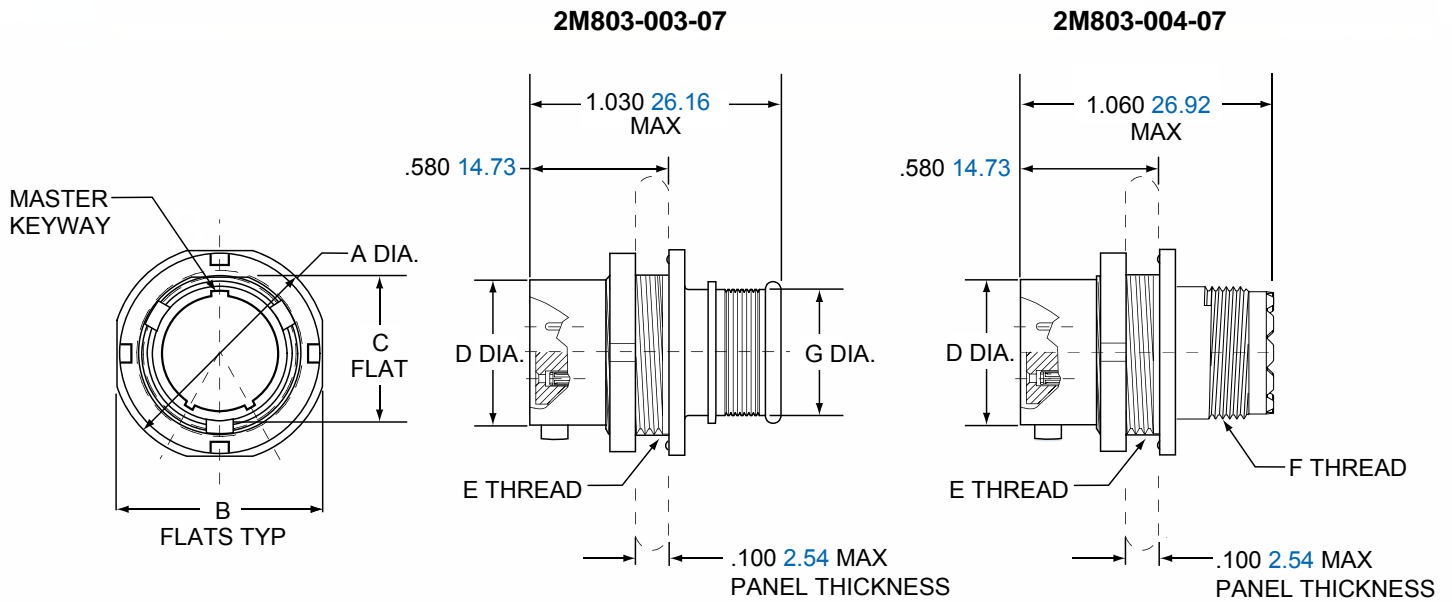

Shell Size	A Dia.		B Flat		C Flat		D Dia.		E Thread	F Thread	G Dia.	
	in.	mm.	in.	mm.	in.	mm.	in.	mm.			in.	mm.
5	.575	14.61	.545	13.84	.350	8.89	.300	7.62	.3750-32 UNEF-2A	.2500-32 UNEF-2A	.230	5.84
6	.635	16.13	.595	15.11	.410	10.41	.362	9.19	.4375-28 UNEF-2A	.3125-32 UNEF-2A	.286	7.26
7	.755	19.18	.723	18.36	.536	13.61	.436	11.07	.5625-32 UN-2A	.4375-28 UNEF-2A	.390	9.91
8	.755	19.18	.790	20.11	.593	15.10	.508	12.91	.6250-28 UN-2A	.5000-28 UNEF-2A	.440	11.18
9	.830	21.08	.790	20.07	.596	15.14	.561	14.25	.6250-28 UN-2A	.5625-24 UNEF-2A	.500	12.70
10	.890	22.61	.925	23.51	.721	18.31	.635	16.13	.7500-28 UN-2A	.6250-24 UNEF-2A	.562	14.27
12	1.078	27.38	1.044	26.52	.845	21.46	.714	18.14	.8750-28 UN-2A	.6875-24 UNEF-2A	.650	16.51
14	1.264	32.11	1.230	31.24	1.022	25.96	.865	21.97	1.0625-20 UN-2A	.9375-20 UNEF-2A	.805	20.45

PANEL CUTOUT FOR JAM NUT RECEPTACLE

Shell Size	A Flat		B Dia.	
	in. ±.002	mm. ± 0.05	in.	mm.
5	.355	9.02	.382	9.70
6	.415	10.54	.445	11.30
7	.541	13.74	.572	14.53
8	.603/.599	15.32/15.21	.635	16.13
9	.601	15.27	.643	16.33
10	.731/.727	18.57/18.47	.760	18.29
12	.850	21.59	.885	22.48
14	1.031	23.19	1.072	27.23

2M803 1/4 Turn Bayonet Coupling Flange Mount

2M803-003-02 and 2M803-004-02

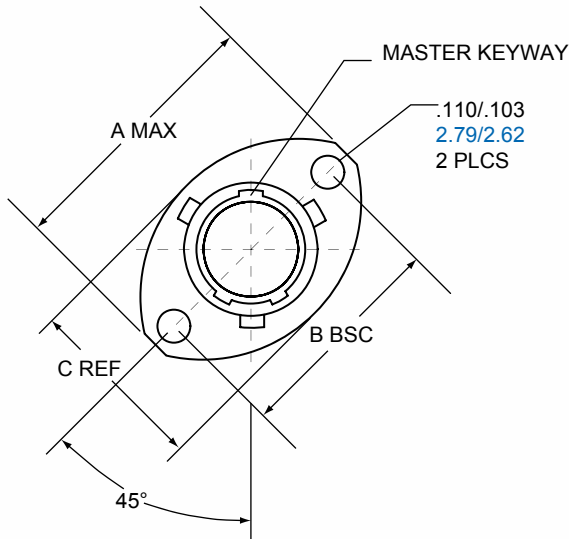

2M803-003-02

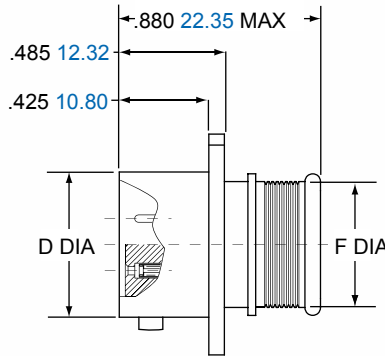

2M803-004-02

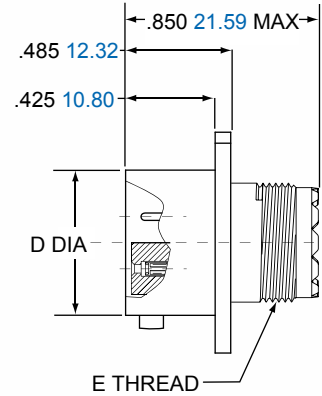

2M803

Shell Size	A Max.		B BSC.		C Ref.		D Dia.		E Thread	F Dia.	
	in.	mm.	in.	mm.	in.	mm.	in.	mm.		in.	mm.
5	.703	17.86	.513	13.03	.460	11.68	.300	7.62	.2500-32 UNEF-2A	.230	5.84
6	.788	20.02	.598	15.19	.522	13.26	.362	9.19	.3125-32 UNEF-2A	.286	7.26
7	.890	22.61	.708	17.98	.590	14.99	.436	11.07	.4375-28 UNEF-2A	.390	9.91
8	1.154	29.31	.964	24.49	.668	16.97	.508	12.91	.5000-28 UNEF-2A	.440	11.18
9	1.207	30.66	1.017	25.83	.721	18.31	.561	14.25	.5625-24 UNEF-2A	.500	12.70
10	1.291	32.79	1.101	27.97	.795	20.19	.635	16.13	.6250-24 UNEF-2A	.562	14.27
12	1.394	35.41	1.204	30.58	.874	22.20	.714	18.14	.6875-24 UNEF-2A	.650	16.51
14	1.545	39.24	1.280	32.51	1.050	26.67	.865	21.97	.9375-20 UNEF-2A	.805	20.45

FLANGE MOUNT PANEL CUTOUTS

Shell Size	A		B Dia	
	in.	mm.	in.	mm.
5	.513	13.03	.365	9.25
6	.598	15.19	.430	10.92
7	.708	17.98	.520	13.21
8	.964	17.98	.592	15.04
9	1.017	25.83	.645	16.38
10	1.101	27.97	.726	18.44
12	1.204	30.58	.832	21.13
14	1.280	32.51	.945	24.00

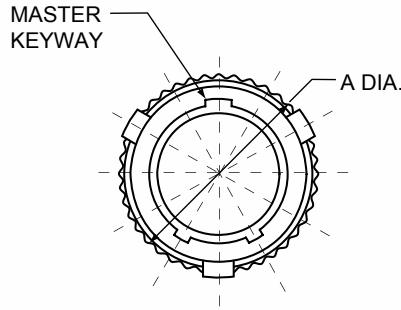

2M803-003-01

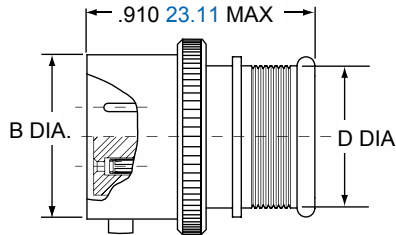

2M803-004-01

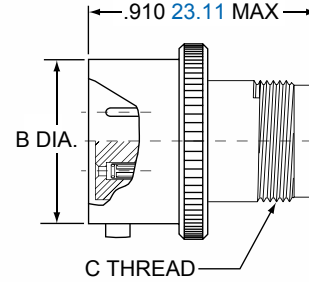

2M803

Shell Size	A Max.		B Dia.		C Thread	D Dia.	
	in.	mm.	in.	mm.		in.	mm.
5	.402	10.21	.300	7.62	.2500-32 UNEF-2A	.230	5.84
6	.465	11.81	.362	9.19	.3125-32 UNEF-2A	.286	7.26
7	.500	12.70	.436	11.07	.4375-28 UNEF-2A	.390	9.91
8	.570	14.48	.508	12.90	.5000-28 UNEF-2A	.440	11.18
9	.652	16.56	.561	14.25	.5625-24 UNEF-2A	.500	12.70
10	.715	18.15	.635	16.13	.6250-24 UNEF-2A	.562	14.27
12	.805	20.45	.714	18.14	.6875-24 UNEF-2A	.650	16.51
14	.915	23.24	.865	21.97	.9375-20 UNEF-2A	.805	20.45

2M803 1/4 Turn Bayonet Coupling PCB

Ordering Guide for 2M803 Printed Circuit Board Receptacles

2M803 Series of PC Board Receptacles

2M803 Series of PC Board Receptacles are intended for use of terminating the connector directly to a Circuit Board or Flex assembly. These connectors however can be supplied with Soldercup termination for direct wire attachment.

2M803 FEATURES INCLUDE:

- Low profile shells for minimum box protrusion
- Shell Standoff's for PC Board washout
- Non-removable PC and/or Soldercup contacts
- Environmental Sealing

2M803

Series	Shell Style	Service Class	Shell Size-Insert Arrg.	Contact Type	Alternate Position
2M803-0XX	-07	ZNU	9-19	P	N

SERIES	
2M803-005	Receptacle for Solder Cup or PCB Termination, with Standard Epoxy Potting
2M803-015	Receptacle with Solder Cup or PCB Termination with Special Sealing for Open Face (unmated) Water Immersion Requirements. 100% Leak Tested. To maintain a helium leak rate of 1-10 ⁻⁴ cc/sec. pressure differential from -40°C to 70° C.

SHELL STYLE	
-02	Flange Mount
-07	Jam Nut

SHELL SIZE - INSERT ARRANGEMENTS
See Insert Arrangements on Pages 7-9

CONTACTS	
P	Pin - PC Tail
S	Socket - PC Tail
E	Pin-Solder Cup
F	Socket-Solder Cup



SERVICE CLASS	
	Finish
C	Aluminum/Black Anodize (Non-Conductive)
M	Aluminum/Electroless Nickel
NF	Aluminum/Cadmium with Olive Drab Chromate
MT	Aluminum/Nickel-PTFE (Durmalon)
Z1	Stainless Steel/Passivated
ZN	Aluminum/Zinc-Nickel w/Olive Drab Chromate
ZNU	Aluminum/Zinc-Nickel with Black Chromate

KEYING		
Key Position	Key Rotation	
	A	B
N (Normal)	150°	210°
X	75°	210°
Y	95°	230°
Z	140°	275°

Receptacle View

2M803-005-02

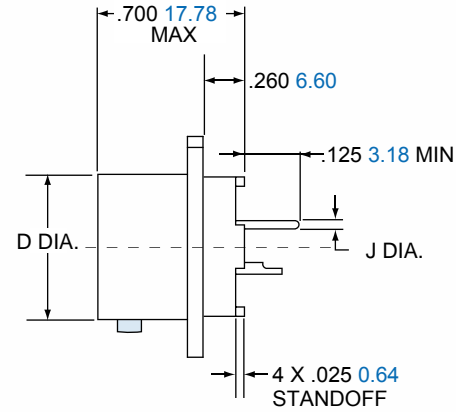
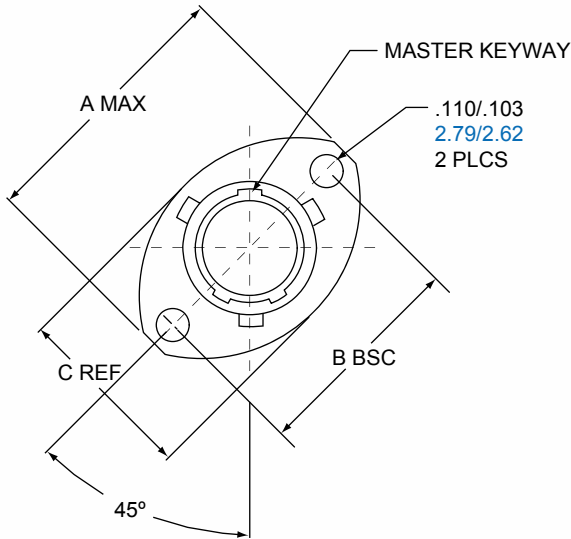

2M803-005-07

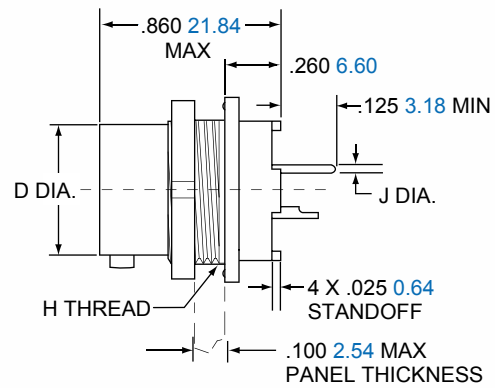
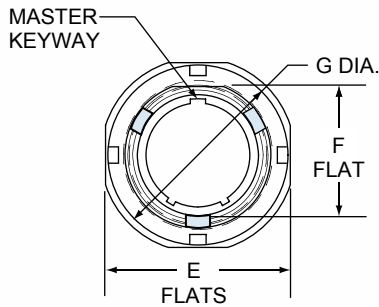

Shell Size	A Max.		B BSC.		C Ref.		D Dia.		E Flats		F Flats		G Dia.		H Thread	J Dia. Tail Dia.
	in.	mm	in.	mm.	in.	mm	in.	mm.	in.	mm.	in.	mm.	in.	mm.		
5	.703	17.86	.513	13.03	.460	11.68	.300	7.62	.545	13.84	.350	8.89	.575	14.61	.3750-32 UNEF-2A	#23
6	.788	20.02	.598	15.19	.522	13.26	.362	9.19	.595	15.11	.410	10.42	.635	16.13	.4375-28 UNEF-2A	.018/.022 0.46/0.56
7	.890	22.61	.708	17.98	.590	14.99	.436	11.07	.723	18.36	.536	13.61	.755	19.18	.5625-32 UN-2A	#16
8	1.154	29.31	.964	24.49	.668	16.97	.508	12.91	.790	20.07	.593	15.10	.755	19.18	.6250-32 UN-2A	.060/.064 1.52/1.63
9	1.207	30.66	1.017	25.83	.721	18.31	.561	14.25	.790	20.07	.596	15.14	.830	21.08	.6250-28 UN-2A	#12
10	1.291	32.79	1.101	27.97	.795	20.19	.635	16.13	.925	23.51	.925	.721	.890	22.61	.7500-28 UN-2A	.092/.096 2.34/2.44
12	1.394	35.41	1.204	30.58	.874	22.20	.714	18.14	1.044	26.52	.845	21.46	1.078	27.38	.8750-28 UN-2A	#12
14	1.545	39.24	1.280	32.51	1.050	26.67	.865	21.97	1.230	31.24	1.022	25.96	1.264	32.11	1.0625-20 UN-2A	#12

2M803 1/4 Turn Bayonet Coupling Hermetic

Ordering Guide for 2M803-006 Receptacles

2M803 Series of Hermetic Receptacles:

2M803 Series of Hermetic Receptacles provide superior sealing of 1×10^{-6} cc/second helium leak rate and are 100% tested prior to shipping. This superior sealing is accomplished through the use of glass insulator fused to stainless steel shells and iron alloy contacts.

2M803 FEATURES INCLUDE:

- Low profile shells for minimum box protrusion
- Shell Standoff's for PC Board washout
- Non-removable PC and/or Soldercup contacts
- Hermetic Sealing

2M803

Series	Shell Style	Service Class	Shell Size-Insert Arrg.	Contact Type	Alternate Position
2M803-006	-07	Z1	6-7	P	N

SERIES	
2M803-006	Hermetic Receptacles with PCB Contacts or Solder Cup Contacts

SHELL SIZE - INSERT ARRANGEMENTS
See Insert Arrangements on Pages 7-9

CONTACTS	
P	Pin-Solder Cup
C	Pin - PC Tail

SHELL STYLE	
-02	Flange Mount
-07	Jam Nut

SERVICE CLASS		
		Finish
Z1		Stainless Steel/Passivated
ZL		Stainless Steel/Nickel Plated



KEYING		
Key Position	Key Rotation	
	A	B
N (Normal)	150°	210°
X	75°	210°
Y	95°	230°
Z	140°	275°

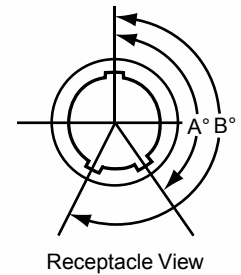

2M803 1/4 Turn Bayonet Coupling

Flange Mount and Jam Nut 2M803-006-02 & -07

2M803-006-02

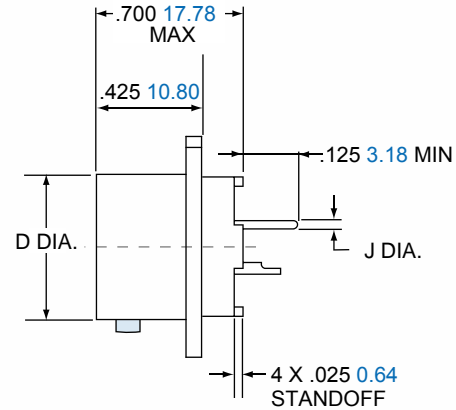
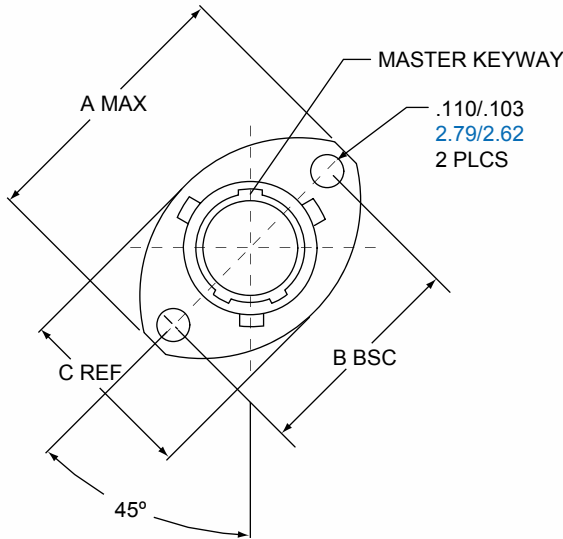

2M803

2M803-006-07

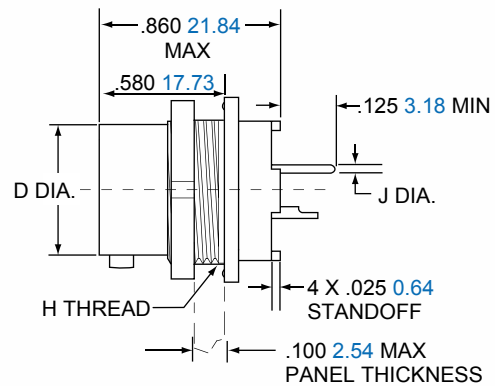
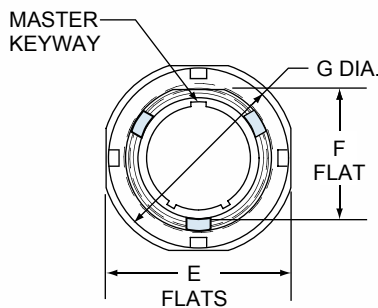

Shell Size	A Max.		B BSC.		C Ref.		D Dia.		E Flats		F Flats		G Dia.		H Thread	J PC Tail Dia.
	in.	mm	in.	mm.	in.	mm	in.	mm.	in.	mm.	in.	mm.	in.	mm.		
5	.703	17.86	.513	13.03	.460	11.68	.300	7.62	.545	13.84	.350	8.89	.575	14.61	.3750-32 UNEF-2A	#23
6	.788	20.02	.598	15.19	.522	13.26	.362	9.19	.595	15.11	.410	10.42	.635	16.13	.4375-28 UNEF-2A	.018/.022 0.46/0.56
7	.890	22.61	.708	17.98	.590	14.99	.436	11.07	.723	18.36	.536	13.61	.755	19.18	.5625-32 UN-2A	
8	1.154	29.31	.964	24.49	.668	16.97	.508	12.91	.790	20.07	.593	15.10	.755	19.18	.6250-32 UN-2A	#16
9	1.207	30.66	1.017	25.83	.721	18.31	.561	14.25	.790	20.07	.596	15.14	.830	21.08	.6250-28 UN-2A	.060/.064 1.52/1.63
10	1.291	32.79	1.101	27.97	.795	20.19	.635	16.13	.925	23.51	.925	.721	.890	22.61	.7500-28 UN-2A	
12	1.394	35.41	1.204	30.58	.874	22.20	.714	18.14	1.044	26.52	.845	21.46	1.078	27.38	.8750-28 UN-2A	#12
14	1.545	39.24	1.280	32.51	1.050	26.67	.865	21.97	1.230	31.24	1.022	25.96	1.264	32.11	1.0625-20 UN-2A	.092/.096 2.34/2.44

2M803 1/4 Turn Bayonet Coupling

Ordering Guide for Protection Caps 2M660-082 & 2M660-083



2M803

Series	Service Class	Attachment Type	Shell Size	Attachment Code	Attachment Length in Inches
2M660-082	-M	-G	6	04	-5

SERIES	
2M660-082	Protection Cap for Bayonet Plug Connectors
2M660-083	Protection Cap for Bayonet Receptacle Connectors

ATTACHMENT TYPE	SHELL SIZE
-G Nylon Rope	5
-H Stainless Steel Wire Rope, Teflon® Jacket	6
-N No Attachment	7
-S Stainless Steel Sash Chain	8
-SK Nylon Rope With Slip Knot	9
-T Stainless Steel Wire Rope, No Jacket	10
-U Stainless Steel Wire Rope, Polyurethane Jacket	12
	14

Omit for attachment Type N (No Attachment)
Example "-5" equals five inch length

ATTACHMENT CODE	
Omit for attachment Types N (No Attachment) and SK (Slip Knot)	
Small Ring	01 -.126 (3.20) I.D.
	02 -.145 (3.68) I.D.
	04 -.188 (4.78) I.D.
	06 -.197 (5.00) I.D.
Large Ring	14 -.385 (9.78) I.D.
	15 -.445 (11.30) I.D.
	16 -.570 (14.48) I.D.
	17 -.635 (16.13) I.D.
	18 -.695 (17.65) I.D.
	19 -.885 (22.48) I.D.
Split Ring	20 -1.070 (27.17) I.D.
	50 -.420 (10.67) I.D.
	52 -.480 (12.19) I.D.
	54 -.635 (16.13) I.D.
	56 -.745 (18.92) I.D.
	58 -.885 (22.48) I.D.
	60 -1.010 (25.65) I.D.
	64 -1.125 (28.58) I.D.
	68 -1.345 (34.16) I.D.

SERVICE CLASS		
		Finish
C		Aluminum/Black Anodize (Non-Conductive)
M		Aluminum/Electroless Nickel
NF		Aluminum/Cadmium with Olive Drab Chromate
MT		Aluminum/Nickel-PTFE (Durmalon)
Z1		Stainless Steel/Passivated
ZN		Aluminum/Zinc-Nickel w/Olive Drab Chromate
ZNU		Aluminum/Zinc-Nickel with Black Chromate



2M660-082

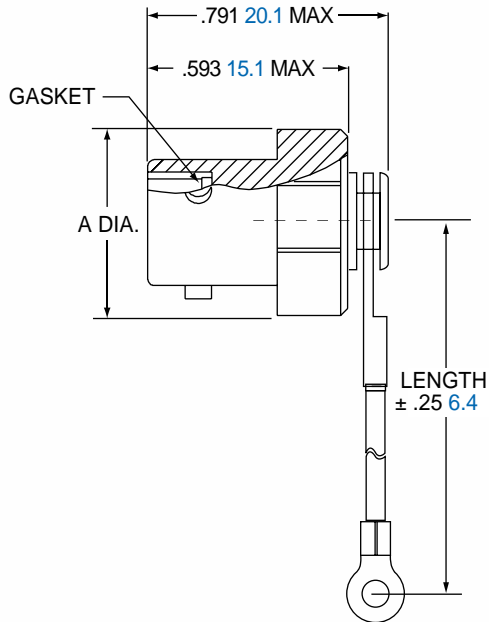

2M660-083

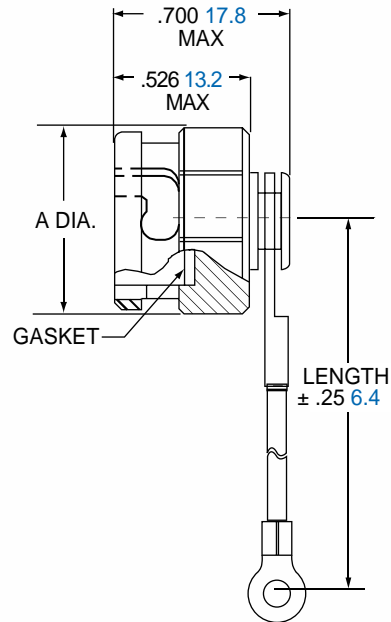



Shell Size	A Max.	
	in.	mm.
5	.620	15.7
6	.620	15.7
7	.620	15.7
8	.690	17.5
9	.760	19.3
10	.850	21.6
12	.940	23.8
14	1.170	29.7

MATERIALS

Cover	Aluminum alloy or stainless steel
Gasket	Fluorosilicone rubber
Wire, Hardware	Stainless steel, passivated

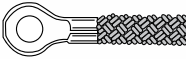
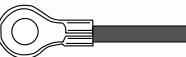
LANYARD OPTIONS

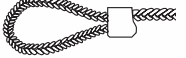
	Nylon Rope	-55° to +100°C., black, flexible, good abrasion resistance, good resistance to fuels, .120" 3mm diameter
	Polyurethane Coated Wire Rope	Black polyurethane over stainless steel rope, very flexible, excellent abrasion resistance, excellent resistance to fuels, .080" 2mm diameter
	Teflon® Jacketed Wire Rope	Translucent FEP jacket over stainless steel, -55° to +200°C., fair flexibility, good abrasion resistance, .100" diameter
	Sash Chain	Stainless steel
	Slip Knot (SK) for attaching Covers to Cables	55° to +100°C., black, flexible, good abrasion resistance, good resistance to fuels, .120" 3mm diameter. Length includes .5" 13mm diameter loop.

General Information

2M804 Series Micro Miniature Connectors:

Amphenol's 2M804 Series of connectors is ideal for applications where space is limited and a quick disconnect connector is needed. The series features a push to mate, pull to un-mate connectors with EMI spring installed in the receptacle for improved EMI. Plugs and Receptacles are provided in two different styles to accommodate the attachment of backshell with rear accessory threads or with integral backshell. The integral backshell allows for use of EMI shielding attachments and/or overmolding. Contact termination styles include Crimp, PC Tail, and Solder cup with others available upon request. Custom and Filter configuration are available, please consult factory for ordering information.

2M804 FEATURES INCLUDE:

- Push to mate, Pull to un-mate coupling
- Flush mounting Receptacle on outside of panel
- Sealed Receptacles:
 - Hermetic (1×10^{-6} cc/second)
 - Epoxy Backfilled (1×10^{-4} cc/second)
- ROHS Compliant Platings available
- Insert Arrangements up to 55 contacts



2M804

2M804 SPECIFICATIONS

Current Rating	See Insert Arrangements (p.7-9)
DWV	See Insert Arrangements (p.7-9)
Insulation Resistance	5000 megohms min.
Operating Temperature	-65° C to +150° C
Shock	300 g's
Random Vibration	37 g's
Shielding Effectiveness	60 dB min. from 100MHz to 1000MHz
Durability	2000 mating cycles

2M804 MATERIALS AND FINISHES

Shells	Aluminum Alloy or Stainless Steel
Contacts	Copper Alloy, gold plated
Insulators	Polyphenylene Sulfide (PPS)
Contact Retention	Beryllium Copper Alloy
Grommet, Interfacial Seal, O'Ring	Fluorosilicone Rubber
Canted Coil Spring	Stainless Steel, Gold plated

SERIES 2M804 WEIGHTS IN GRAMS

Insert Arr.	Plug	Jam Nut Receptacle		In-Line Receptacle
		Rear Mount	Front Mount	
5-3P	2.2	8.0	9.7	4.0
5-3S	2.4	8.3	9.8	4.1
6-1P	3.1	7.2	11.8	5.2
6-1S	3.4	7.5	12.1	5.5
6-4P	2.8	8.8	11.4	4.8
6-4S	3.0	9.0	11.6	5.1
6-7P	3.0	9.1	11.7	5.3
6-7S	3.2	9.5	12.0	5.5
7-1P	3.7	11.1	16.4	10.1
7-1S	4.3	11.7	16.9	10.7
7-10P	3.7	10.9	16.2	10.0
7-10S	4.2	11.3	16.5	10.3
8-2P	5.0	10.9	13.5	8.0
8-2S	5.7	5.7	11.7	9.0
8-13P	4.3	10.6	12.4	7.4
8-13S	4.8	11.0	13.0	8.1
8-200P	5.3	11.2	13.9	8.4
8-200S	6.1	12.0	14.6	9.1
9-4P	5.7	15.2	21.1	11.0
9-4S	6.7	16.2	22.1	12.0
9-19P	4.6	14.1	20.0	9.9
9-19S	4.8	14.9	21.1	9.8
9-200P	5.2	14.6	20.6	10.5
9-200S	6.3	15.7	21.7	11.6
9-201P	5.8	15.3	21.2	11.1
9-201S	6.9	16.4	22.3	12.2
10-5P	7.3	15.5	23.3	11.9
10-5S	8.7	16.9	24.8	13.3
10-26P	5.4	13.6	20.5	10.1
10-26S	6.2	13.9	21.1	10.5
10-200P	6.2	14.4	22.2	10.8
10-200S	7.6	15.8	23.7	12.2
10-201P	6.3	14.5	22.3	10.9
10-201S	7.7	16.0	23.8	12.3
10-202P	6.3	14.5	22.3	10.9
10-202S	7.8	16.1	23.9	12.4
12-2P	10.7	21.5	26.1	20.8
12-2S	12.3	23.1	27.7	22.4
12-3P	11.7	22.4	27.1	21.8
12-3S	13.4	24.2	28.8	23.4
12-7P	11.9	22.7	27.3	22.0

SERIES 2M804 WEIGHTS IN GRAMS

Insert Arr.	Plug	Jam Nut Receptacle		In-Line Receptacle
		Rear Mount	Front Mount	
12-7S	14.5	25.3	29.9	24.6
12-37P	10.1	21.5	25.5	22.4
12-37S	11.8	23.1	27.2	22.1
12-200P	10.3	21.1	25.7	20.5
12-200S	12.5	23.3	27.9	22.7
12-201P	10.7	21.5	26.1	22.8
12-201S	13.0	23.8	28.4	23.1
14-5P	15.4	28.3	33.6	26.3
14-5S	18.4	31.2	36.5	29.3
14-12P	16.2	29.0	34.3	27.1
14-12S	19.8	32.7	38.0	30.7
14-55P	12.8	25.6	30.9	23.7
14-55S	15.6	28.3	33.8	26.5

SERIES 2M804 UNMATE FORCE

Layout	Average Force	
	Pounds	Newtons
5-3	10.6	47.1
6-4	10.8	48.0
6-7	11.4	50.7
7-10	12.0	53.4
8-13	12.6	56.0
9-19	13.8	61.4
10-26	15.2	67.6
12-37	17.4	77.4
14-55	21.0	93.4

2M804 Push-Pull Crimp Receptacles

Ordering Guide for 2M804-001, 002, 003, 004

1.	2.	3.	4.	5.	6.
Series	Shell Style	Service Class	Shell Size-Insert Arrg.	Contact Type	Alternate Position
2M804-00X	-06	ZNU	6-7	P	

For single master key omit (leave blank)

SERIES	
2M804-001	Plug with Intergral Backshell
2M804-002	Plug with Accessory Thread
2M804-003	Receptacle with Intergral Backshell
2M804-004	Receptacle with Accessory Thread

SHELL SIZE - INSERT ARRANGEMENTS

See Insert Arrangements on Pages 7-9



CONTACTS	
P	Pin
S	Socket

SHELL STYLE	
2M804-001 2M804-002	
-06	Plug
SHELL STYLE	
2M804-003 2M804-004	
-00	Jam Nut for Front Panel Mounting
-01	In-Line for Free-Hanging Cable
-07	Jam Nut for Rear Panel Mounting

SERVICE CLASS	
Finish	
C	Aluminum/Black Anodize (Non-Conductive)
M	Aluminum/Electroless Nickel
NF	Aluminum/Cadmium with Olive Drab Chromate
MT	Aluminum/Nickel-PTFE (Durmalon)
Z1	Stainless Steel/Passivated
ZN	Aluminum/Zinc-Nickel w/Olive Drab Chromate
ZNU	Aluminum/Zinc-Nickel with Black Chromate

KEYING		
Key Position	Key Rotation	
	A	B
A (Normal)	150°	210°
B	75°	210°
C	95°	230°
D	140°	275°

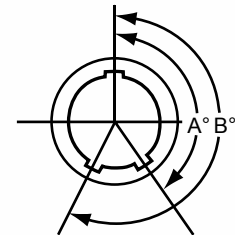

Receptacle View

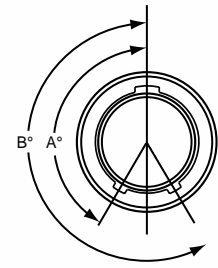

Plug View

INSERT ARRANGEMENTS

Insert Arr.	No. of Contacts				
	#23	#20	#20HD	#16	#12
5-3	3				
6-1				1	
6-4	4				
6-6	6				
6-7	7				
6-23			3		
7-1					1
7-10	10				
7-25			5		
8-2				2	
8-28			8		
8-13	13				
8-200	4	2			
9-4				4	
9-19	19				
9-200	4			2	
9-201	8	2			
9-210			10		
10-2					2

INSERT ARRANGEMENTS

Insert Arr.	No. of Contacts				
	#23	#20	#20HD	#16	#12
10-5				5	
10-26	26				
10-200	12				1
10-201	4				2
10-202	8			2	
12-2					2
12-3					3
12-7				7	
12-37	37				
12-200	6				2
12-201	10				2
12-220			20		
14-5					5
14-12				12	
14-55	55				
14-235			35		

2M804

2M804 Push-Pull Plug Connector

2M804-001-06 and 2M804-002-06

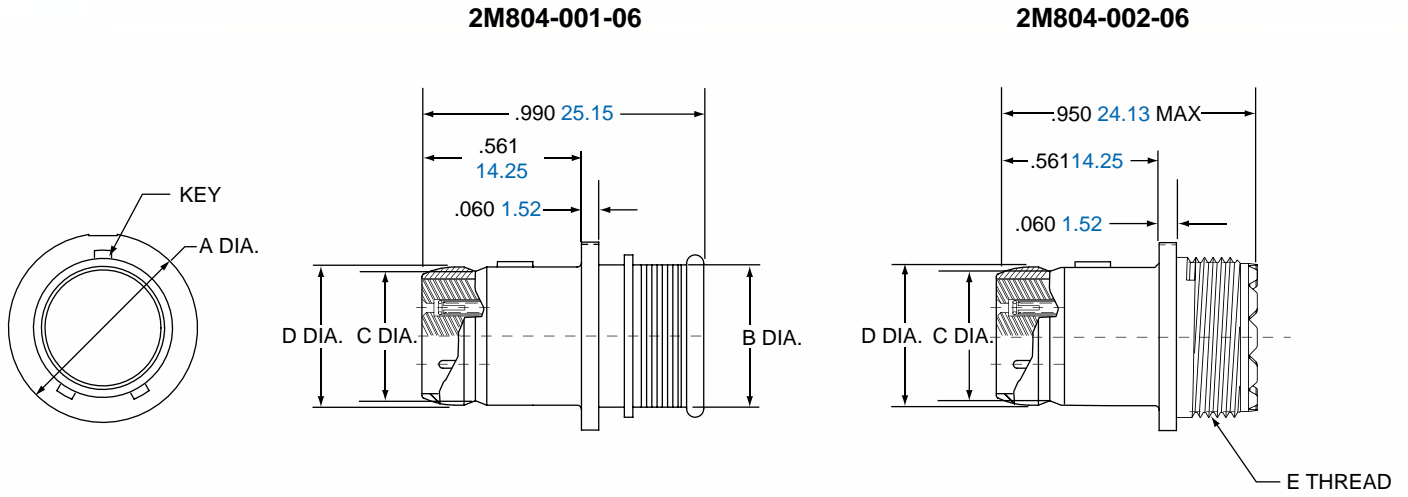

2M804

Shell Size	A Dia.		B Dia.		C Dia.		D Dia.		E Thread
	in.	mm	in.	mm.	in.	mm	in.	mm.	
5	.427	10.85	.246	6.25	.219	5.56	.250	6.35	.2500-32 UNEF-2A
6	.495	12.57	.286	7.26	.282	7.16	.313	7.95	.3125-32 UNEF-2A
7	.575	14.61	.390	9.91	.351	8.92	.383	9.73	.4375-28 UNEF-2A
8	.614	15.60	.442	11.23	.398	10.11	.429	10.90	.5000-28 UNEF-2A
9	.670	17.02	.500	12.70	.454	11.53	.486	12.34	.5625-24 UNEF-2A
10	.745	18.92	.564	14.33	.529	13.44	.563	14.30	.6250-24 UNEF-2A
12	.865	21.97	.650	16.51	.646	16.41	.676	17.17	.6875-24 UNEF-2A
14	.985	25.02	.805	20.45	.768	19.51	.800	20.32	.9375-20 UNEF-2A

2M804 Push-Pull Jam Nut Rear Panel

2M804-004-07 and 2M804-003-07

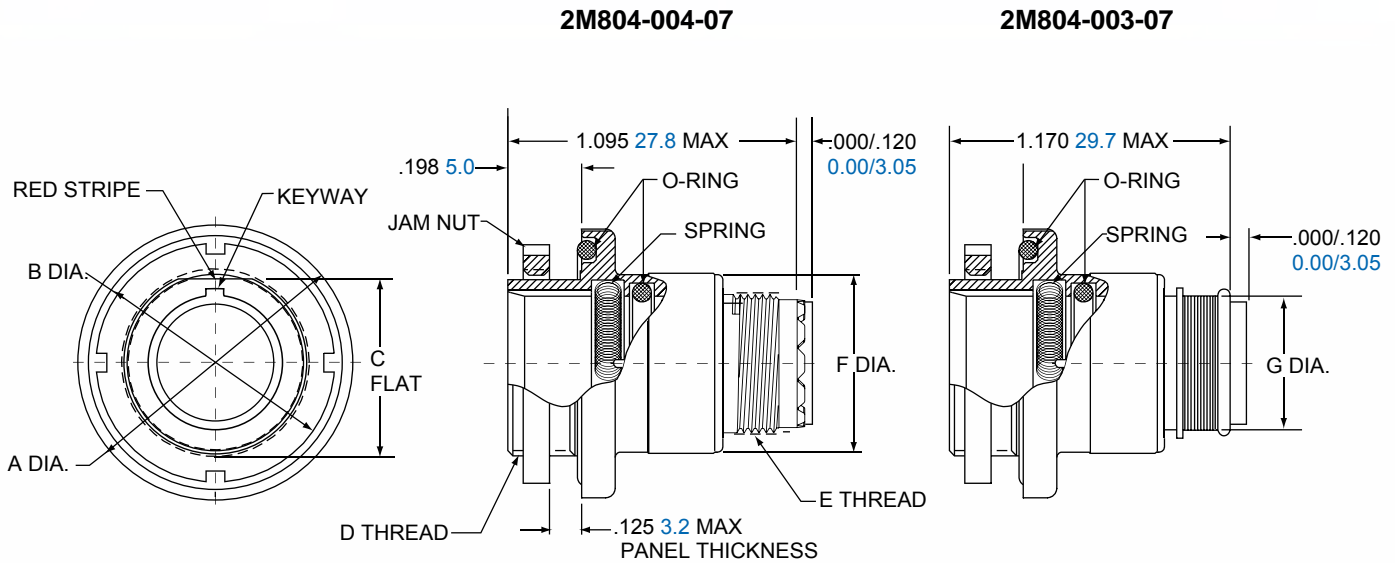

2M804

*Grommet protrudes for power/combo arrangements

Shell Size	A Dia.		B Dia.		C Flat		D Thread	E Thread	F Dia.		G Dia.	
	in.	mm	in.	mm.	in.	mm			in.	mm.	in.	mm.
5	.790	20.07	.562	14.27	.415	10.54	.4375-32 UN-2A	.2500-32 UNEF-2A	.450	11.43	.246	6.25
6	.830	21.08	.625	15.87	.467	14.40	.5000-32 UN-2A	.3125-32 UNEF-2A	.520	13.21	.286	7.26
7	.910	23.11	.750	19.05	.594	15.09	.6250-28 UN-2A	.4375-28 UNEF-2A	.580	14.73	.390	9.91
8	.955	24.26	.750	19.05	.594	15.09	.6250-28 UN-2A	.5000-28 UNEF-2A	.603	15.32	.442	11.23
9	1.000	25.40	.812	20.62	.655	16.64	.6875-28 UN-2A	.5625-24 UNEF-2A	.695	17.65	.500	12.70
10	1.085	27.48	.875	22.22	.721	18.31	.7500-28 UN-2A	.6250-24 UNEF-2A	.735	18.67	.564	14.33
12	1.180	29.97	1.000	25.40	.843	21.41	.8750-28 UN-2A	.6875-24 UNEF-2A	.880	22.35	.650	16.51
14	1.325	33.66	1.125	28.57	.968	24.59	1.0000-28 UN-2A	.9375-20 UNEF-2A	1.010	25.65	.805	20.45

JAM NUT PANEL CUTOUT

Shell Size	A Flat		B Dia.	
	in. ±.002	mm. ± 0.05	in. ±.005	mm. ± 0.13
5	.423	10.74	.448	11.38
6	.475	12.07	.510	12.95
7	.588	14.94	.635	16.13
8	.602	15.29	.635	16.13
9	.663	16.84	.698	17.73
10	.729	18.82	.760	19.30
12	.851	21.62	.885	22.48
14	.976	24.79	1.010	25.65

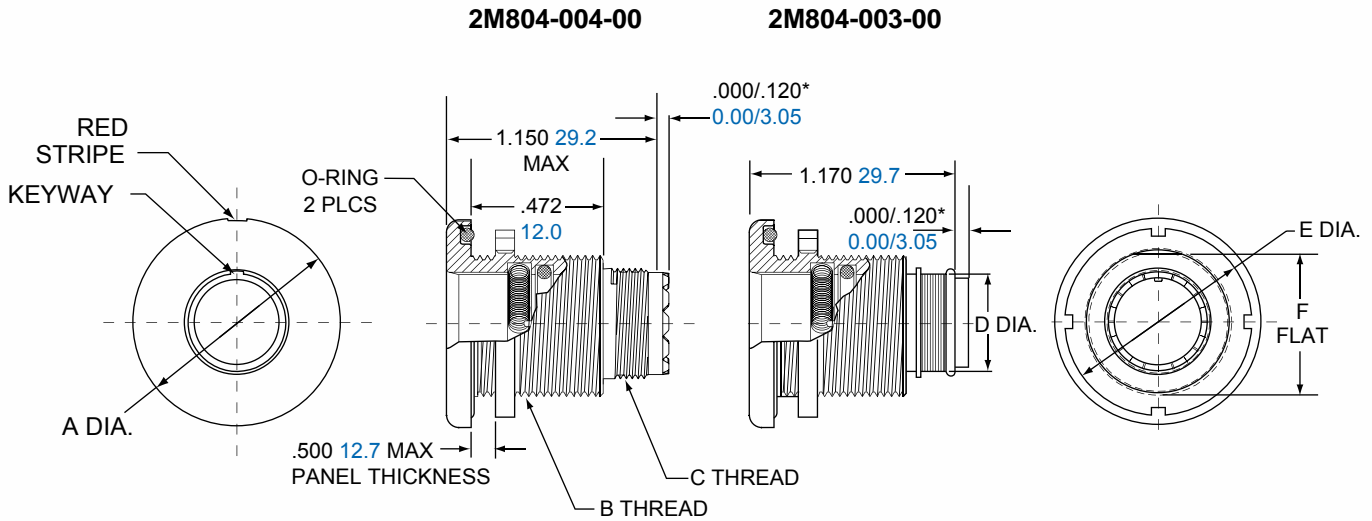

*Grommet protrudes for power/combo arrangements

Shell Size	A Dia.		B Thread	C Thread	D Dia.		E Dia.		F Flat.	
	in.	mm			in.	mm.	in.	mm.	in.	mm.
5	.830	21.08	.5000-32 UN-2A	.2500-32 UNEF-2A	.246	6.25	.625	15.87	.470	11.94
6	.885	22.48	.5625-32 UN-2A	.3125-32 UNEF-2A	.286	7.26	.688	17.47	.530	13.46
7	.995	25.27	.6875-28 UN-2A	.4375-28 UNEF-2A	.390	9.91	.812	20.62	.663	16.84
8	.955	25.27	.6875-28 UN-2A	.5000-28 UNEF-2A	.442	11.23	.812	20.62	.663	16.84
9	1.075	27.31	.7500-28 UN-2A	.5625-24 UNEF-2A	.500	12.70	.875	22.22	.720	18.29
10	1.140	28.95	.8125-28 UN-2A	.6250-24 UNEF-2A	.564	14.33	.938	23.82	.788	20.02
12	1.340	34.04	1.0000-28 UN-2A	.6875-24 UNEF-2A	.650	16.51	1.125	28.57	.970	24.64
14	1.390	35.31	1.0625-20 UN-2A	.9375-20 UNEF-2A	.805	20.45	1.188	30.18	1.020	25.91

PANEL CUTOUT

Shell Size	A Flat		B Dia.	
	in. ±.002	mm. ± 0.05	in. ±.005	mm. ± 0.13
5	.423	10.74	.448	11.38
6	.475	12.07	.510	12.95
7	.588	14.94	.635	16.13
8	.602	15.29	.635	16.13
9	.663	16.84	.698	17.73
10	.729	18.82	.760	19.30
12	.851	21.62	.885	22.48
14	.976	24.79	1.010	25.65

2M804 Push-Pull In-Line Receptacle

2M804-004-01 and 2M804-003-01

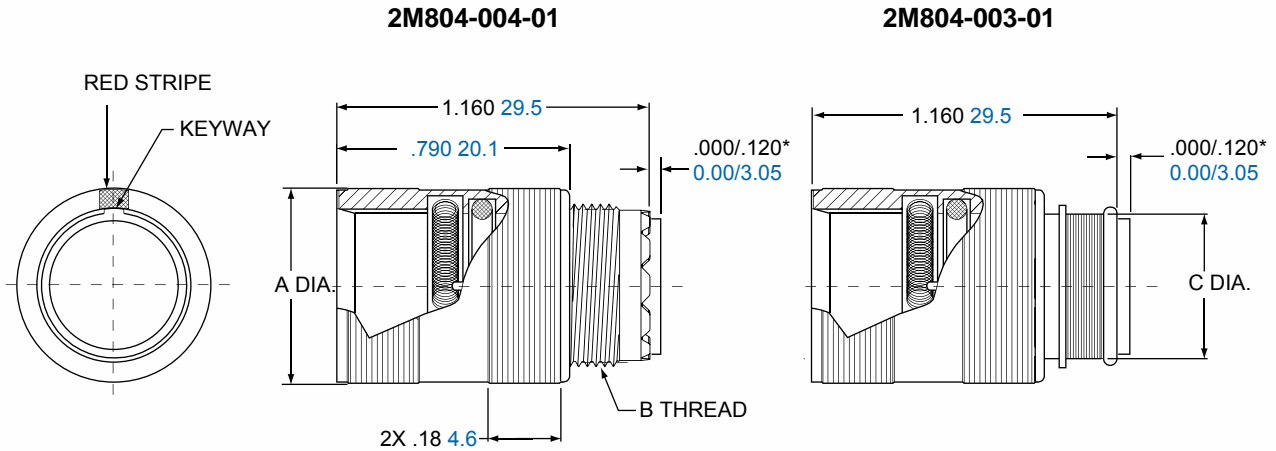

2M804

*Grommet protrudes for power/combo arrangements

Shell Size	A Dia.		B Thread	C Dia.	
	in.	mm		in.	mm.
5	.450	11.43	.2500-32 UNEF-2A	.246	6.25
6	.520	13.21	.3125-32 UNEF-2A	.286	7.26
7	.580	14.73	.4375-28 UNEF-2A	.390	9.91
8	.603	15.32	.5000-28 UNEF-2A	.442	11.23
9	.695	17.65	.5625-24 UNEF-2A	.500	12.70
10	.735	18.67	.6250-24 UNEF-2A	.564	14.33
12	.880	22.35	.6875-24 UNEF-2A	.650	16.51
14	1.010	25.65	.9375-20 UNEF-2A	.805	20.45

2M804 Series of PC Board Receptacles:

2M804 Series of PC Board Receptacles are intended for use of terminating the connector directly to a Circuit Board or Flex assembly. These connectors however can be supplied with Soldercup termination for direct wire attachment.

2M804 FEATURES INCLUDE:

- Flush mounting Receptacle on outside of panel
- Shell Standoff's for PC Board washout
- Non-removable PC and/or Soldercup contacts
- Environmental Sealing



2M804

Series	Shell Style	Service Class	Shell Size-Insert Arrg.	Contact Type	Alternate Position
2M804-0XX	-06	ZNU	9-19	P	

For single master key omit (leave blank)

SERIES	
2M804-005	Receptacle with Solder cup or PCB Termination with Standard Epoxy Potting
2M804-020	Receptacle with Solder Cup or PCB Termination with Special Sealing for Open Face (unmated) Water Immersion Requirements. 100% Leak Tested. To maintain a helium leak rate of 1-10 ⁻⁴ cc/sec. pressure differential from -40°C to 70° C.

SHELL SIZE - INSERT ARRANGEMENTS

See Insert Arrangements on Pages 7-9

CONTACTS	
P	Pin PC Tail
S	Socket PC Tail
E	Pin Solder Cup
F	Socket, Solder Cup

SHELL STYLE	
-00	Jam Nut for Front Panel Mounting
-07	Jam Nut for Rear Panel Mounting

SERVICE CLASS	
	Finish
C	Aluminum/Black Anodize (Non-Conductive)
M	Aluminum/Electroless Nickel
NF	Aluminum/Cadmium with Olive Drab Chromate
MT	Aluminum/Nickel-PTFE (Durmalon)
Z1	Stainless Steel/Passivated
ZN	Aluminum/Zinc-Nickel w/Olive Drab Chromate
ZNU	Aluminum/Zinc-Nickel with Black Chromate

KEYING		
Key Position	Key Rotation	
	A	B
A (Normal)	150°	210°
B	75°	210°
C	95°	230°
D	140°	275°

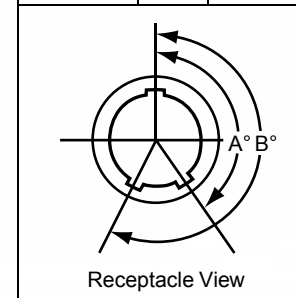

2M804 Push-Pull Rear Panel Jam Nut Receptacle

2M804-005-07, 2M804-020-07

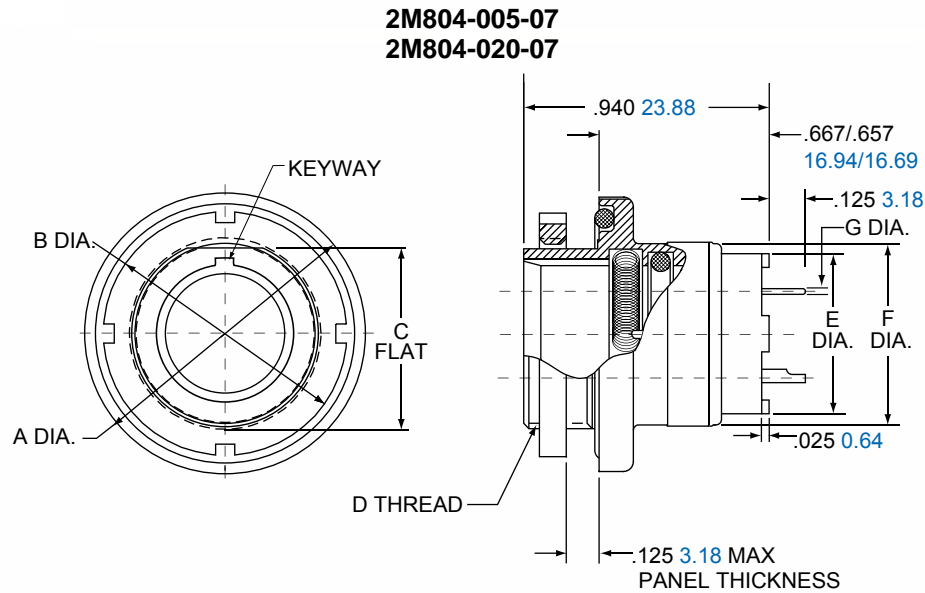

2M804

Shell Size	A Dia.		B Dia.		C Flat		D Thread	E Dia.		F Dia.		G PC Tail Dia.
	in.	mm.	in.	mm.	in.	mm.		in.	mm.	in.	mm.	
5	.730	18.54	.562	14.27	.415	10.54	.4375-32 UN-2A	.275	6.98	.435	11.05	#23 .018/.022 0.46/0.56
6	.730	18.54	.625	15.87	.467	14.40	.5000-32 UN-2A	.330	8.38	.483	12.27	#20 .024/.028 0.61/0.71
7	.910	23.11	.750	19.05	.594	15.09	.6250-28 UN-2A	.432	10.97	.570	14.48	#16 .060/.064 1.52/1.63
8	.955	24.26	.750	19.05	.594	15.09	.6250-28 UN-2A	.493	12.52	.593	15.06	#12 .092/.096 2.34/2.44
9	1.000	25.40	.812	20.62	.655	16.64	.6875-28 UN-2A	.551	14.00	.685	17.40	
10	1.085	27.48	.875	22.22	.721	18.31	.7500-28 UN-2A	.620	15.75	.725	18.42	
12	1.190	30.23	1.000	25.40	.843	21.41	.8750-28 UN-2A	.703	17.86	.850	21.59	
14	1.325	33.66	1.125	28.57	.968	24.59	1.0000-28 UN-2A	.863	21.92	.973	24.71	

JAM NUT PANEL CUTOUT

Shell Size	A Flat		B Dia.	
	in. ±.002	mm. ± 0.05	in. ±.005	mm. ± 0.13
5	.423	10.74	.448	11.38
6	.475	12.07	.510	12.95
7	.588	14.94	.635	16.13
8	.602	15.29	.635	16.13
9	.663	16.84	.698	17.73
10	.729	18.82	.760	19.30
12	.851	21.62	.885	22.48
14	.976	24.79	1.010	25.65

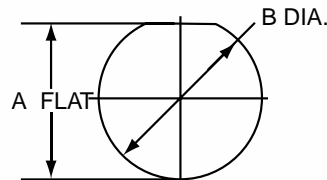

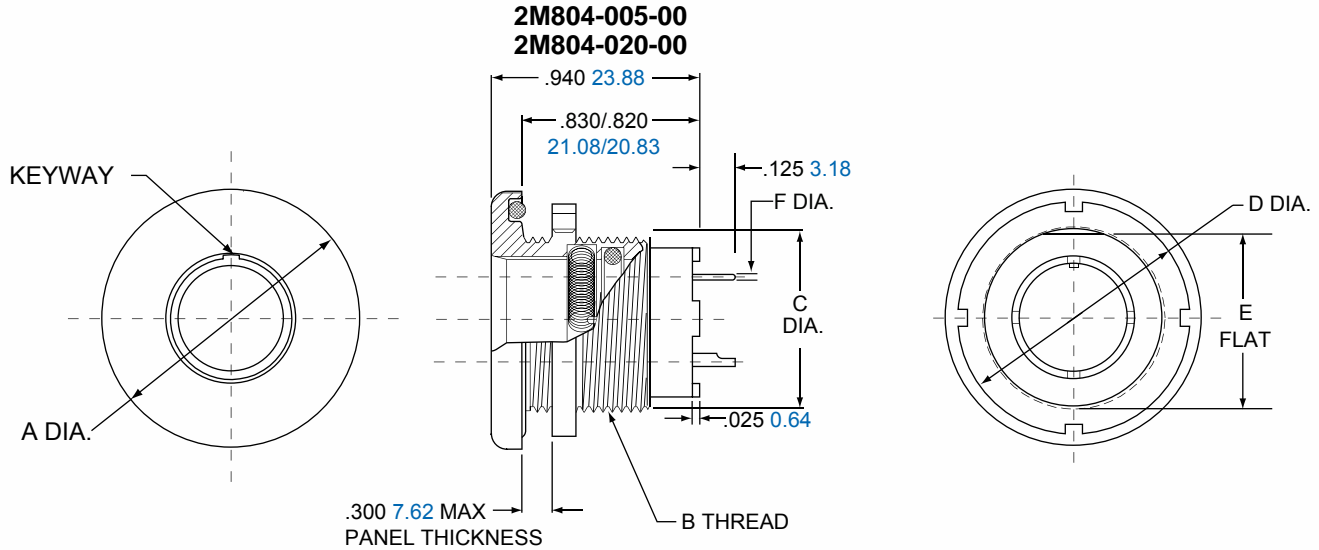

Shell Size	A Dia.		B Thread	C Dia.		D Dia.		E Flat.		F Dia. Tail Dia.
	in.	mm		in.	mm.	in.	mm.	in.	mm.	
5	.830	21.08	.5000-32 UN-2A	.275	6.98	.625	15.87	.470	11.94	#23 .018/.022 0.46/0.56
6	.885	22.48	.5625-28 UN-2A	.330	8.38	.688	17.47	.530	13.46	
7	.995	25.27	.6875-28 UN-2A	.432	10.97	.812	20.62	.663	16.84	#20 .024/.028 0.61/0.71
8	.995	25.27	.6675-28 UN-2A	.493	12.52	.812	20.62	.663	16.84	
9	1.075	27.31	.7500-28 UN-2A	.551	14.00	.875	22.22	.720	18.29	#16 .060/.064 1.52/1.63
10	1.140	28.95	.8125-28 UN-2A	.620	15.75	.938	23.82	.788	20.02	
12	1.340	34.04	1.0000-28 UN-2A	.703	17.86	1.125	28.57	.970	24.64	#12 .092/.096 2.34/2.44
14	1.390	35.31	1.0625-20 UN-2A	.863	21.92	1.188	30.18	1.020	25.91	

JAM NUT PANEL CUTOUT

Shell Size	A Flat		B Dia.	
	in. ±.002	mm. ± 0.05	in. ±.005	mm. ± 0.13
5	.423	10.74	.448	11.38
6	.475	12.07	.510	12.95
7	.588	14.94	.635	16.13
8	.602	15.29	.635	16.13
9	.663	16.84	.698	17.73
10	.729	18.82	.760	19.30
12	.851	21.62	.885	22.48
14	.976	24.79	1.010	25.65

2M804 Push-Pull Plug Panel Mount

Ordering Guide for 2M804-009 and 2M804-021

2M804 Series of Panel Mount Plugs:

2M804 Series of Panel Mount Plugs are intended for use of terminating the connector directly to a Circuit Board or Flex assembly. These connectors can also be supplied with solder cup termination for direct wire attachment.

2M804 FEATURES INCLUDE:

- Low profile shells for minimum box protrusion
- Shell Standoff's for PC Board washout
- Non-removable PC and/or Soldercup contacts
- Environmental Sealing

2M804

Series	Shell Style	Service Class	Shell Size-Insert Arrg.	Contact Type	Alternate Position	
2M804-0XX	-06	ZNU	9-19	P		For single master key omit (leave blank)

SERIES	
2M804-009	Plugs with Solder Cup or PCB Termination with Standard Epoxy Potting
2M804-021	Plugs with Solder Cup or PCB Termination with Special Sealing for Open Face (unmated) Water Immersion Requirements. 100% Leak Tested. To maintain a helium leak rate of 1-10 ⁻⁴ cc/sec. pressure differential from -40°C to 70° C.

SHELL STYLE	
-00	Jam Nut for Front Panel Mounting
-07	Jam Nut for Rear Panel Mounting
-02	Flange Mount, Rear Panel

SERVICE CLASS		
		Finish
C		Aluminum/Black Anodize (Non-Conductive)
M		Aluminum/Electroless Nickel
NF		Aluminum/Cadmium with Olive Drab Chromate
MT		Aluminum/Nickel-PTFE (Durmalon)
Z1		Stainless Steel/Passivated
ZN		Aluminum/Zinc-Nickel w/Olive Drab Chromate
ZNU		Aluminum/Zinc-Nickel with Black Chromate

CONTACTS		
P		Pin PC Tail
S		Socket PC Tail
E		Pin Solder Cup
F		Socket Solder Cup

KEYING		
Key Position	Key Rotation	
	A	B
A (Normal)	150°	210°
B	75°	210°
C	95°	230°
D	140°	275°

Plug View

2M804 Push-Pull Jam Nut Panel Mount

2M804-009-07 and 2M804-021-07

2M804-009-07
2M804-021-07

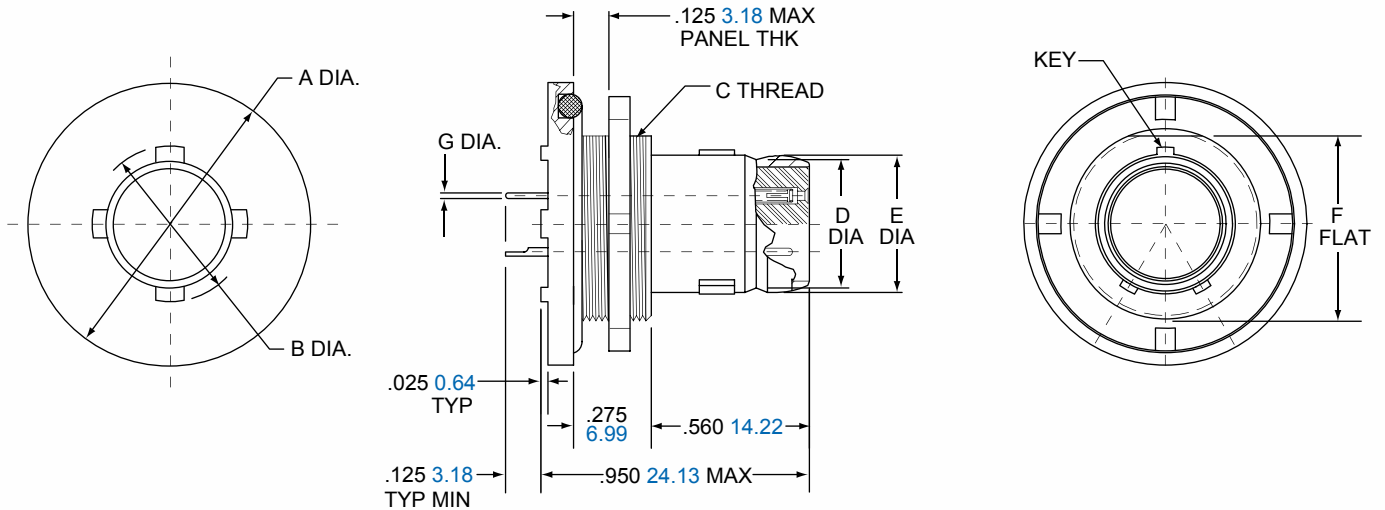

2M804

Shell Size	A Dia.		B Dia.		C Thread	D Dia.		E Dia.		F Flat.		F PC Tail Dia.
	in.	mm.	in.	mm.		in.	mm.	in.	mm.	in.	mm.	
5	.790	20.07	.244	6.20	.4375-32 UN-2A	.219	5.56	.250	6.35	.415	10.54	#23 .018/.022 0.46/0.56
6	.830	21.08	.330	8.38	.5000-32 UN-2A	.282	7.16	.313	7.95	.467	11.86	#20 .024/.028 0.61/0.71
7	.910	23.11	.432	10.97	.6250-28 UN-2A	.351	8.92	.383	9.73	.594	15.09	#16 .060/.064 1.52/1.63
8	.955	24.26	.493	12.52	.6250-28 UN-2A	.398	10.11	.429	10.90	.594	15.09	#12 .092/.096 2.34/2.44
9	1.000	25.40	.551	14.00	.6875-28 UN-2A	.454	11.53	.486	12.34	.655	16.64	
10	1.085	27.56	.620	15.75	.7500-28 UN-2A	.529	13.44	.563	14.30	.721	18.31	
12	1.180	29.97	.703	17.86	.8750-28 UN-2A	.646	16.41	.676	17.17	.843	21.41	
14	1.325	33.66	.863	21.92	1.0000-28 UN-2A	.768	19.51	.800	20.32	.968	24.59	

JAM NUT PANEL CUTOUT

Shell Size	A Flat		B Dia.	
	in. ±.002	mm. ± 0.05	in. ±.005	mm. ± 0.13
5	.423	10.74	.448	11.38
6	.475	12.07	.510	12.95
7	.588	14.94	.635	16.13
8	.602	15.29	.635	16.13
9	.663	16.84	.698	17.73
10	.729	18.82	.760	19.30
12	.851	21.62	.885	22.48
14	.976	24.79	1.010	25.65

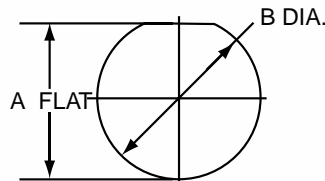

2M804 Push-Pull Front Panel Jam Nut Receptacle

2M804-009-00, 2M804-021-00

2M804-009-00
2M804-021-00

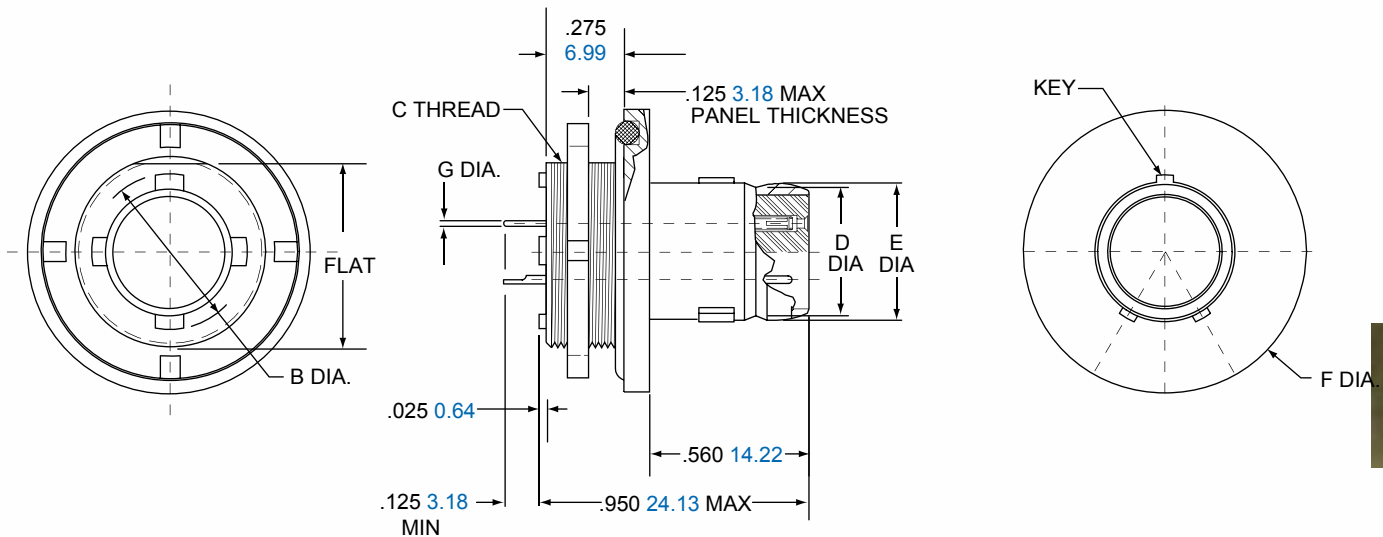

2M804

Shell Size	A Flat.		B Dia.		C Thread	D Dia.		E Dia.		F Dia.		G PC Tail Dia.
	in.	mm.	in.	mm.		in.	mm.	in.	mm.	in.	mm.	
5	.415	10.54	.244	6.20	.4375-32 UN-2A	.219	5.56	.250	6.35	.790	20.07	#23 .018/.022 0.46/0.56
6	.467	11.86	.330	8.38	.5000-32 UN-2A	.282	7.16	.313	7.95	.830	21.08	
7	.594	15.09	.432	10.97	.6250-28 UN-2A	.351	8.92	.383	9.73	.910	23.11	#20 .024/.028 0.61/0.71
8	.594	15.09	.493	12.52	.6250-28 UN-2A	.398	10.11	.429	10.90	.955	24.26	
9	.655	16.64	.551	14.00	.6875-28 UN-2A	.454	11.53	.486	12.34	1.000	25.40	#16 .060/.064 1.52/1.63
10	.721	18.31	.620	15.75	.7500-28 UN-2A	.529	13.44	.563	14.30	1.085	27.56	
12	.843	21.41	.703	17.86	.8750-28 UN-2A	.646	16.41	.676	17.17	1.180	29.97	#12 .092/.096 2.34/2.44
14	.968	24.59	.863	21.92	1.0000-28 UN-2A	.768	19.51	.800	20.32	1.325	33.66	

JAM NUT PANEL CUTOUT

Shell Size	A Flat		B Dia.	
	in. ±.002	mm. ± 0.05	in. ±.005	mm. ± 0.13
5	.423	10.74	.448	11.38
6	.475	12.07	.510	12.95
7	.588	14.94	.635	16.13
8	.602	15.29	.635	16.13
9	.663	16.84	.698	17.73
10	.729	18.82	.760	19.30
12	.851	21.62	.885	22.48
14	.976	24.79	1.010	25.65

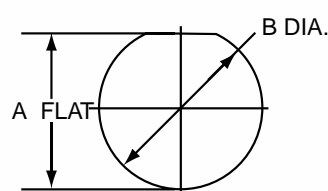

2M804 Push-Pull Plug Flange Panel Mount

2M804-009-02 and 2M804-021-02

2M804-009-02
2M804-021-02

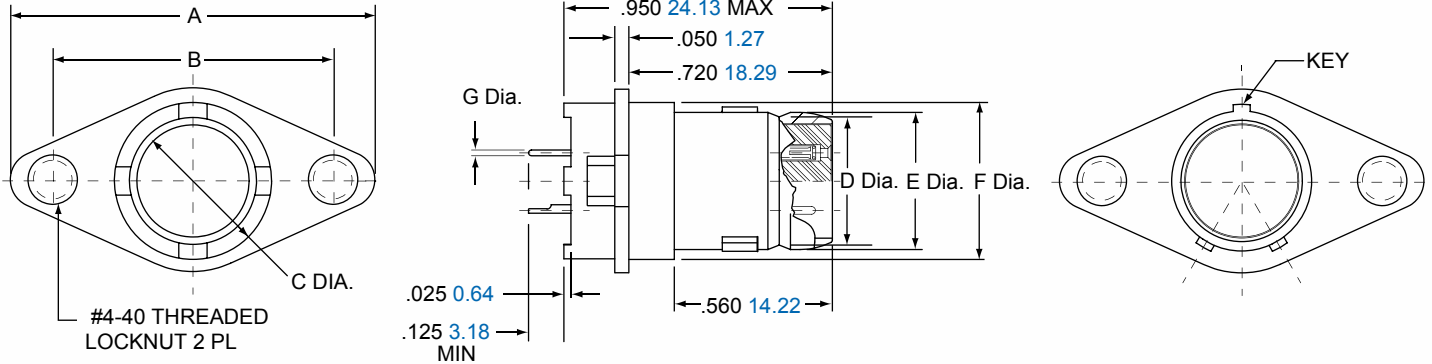

2M804

Shell Size	A		B		C Dia.		D Dia.		E Dia.		F Dia.		G PC Tail Dia.
	in.	mm.	in. ± .005	mm. ± 0.13	in.	mm.	in.	mm.	in.	mm.	in.	mm.	
5	1.055	26.80	.755	19.18	.244	6.20	.219	5.56	.250	6.35	.320	8.13	#23 .018/.022 0.46/0.56
6	1.120	28.45	.820	20.83	.330	8.38	.282	7.16	.313	7.95	.385	9.78	
7	1.185	30.10	.885	22.48	.432	10.97	.351	8.92	.383	9.73	.450	11.43	#20 .024/.028 0.61/0.71
8	1.230	31.24	.930	23.62	.493	12.52	.398	10.11	.429	10.90	.495	12.57	
9	1.290	32.77	.990	25.15	.551	14.00	.454	11.53	.486	12.34	.555	14.10	#16 .060/.064 1.52/1.63
10	1.360	34.54	1.060	26.92	.620	15.75	.529	13.44	.563	14.30	.625	15.88	
12	1.485	37.72	1.185	30.10	.703	17.86	.646	16.41	.676	17.17	.750	19.05	#12 .092/.096 2.34/2.44
14	1.600	40.64	1.300	33.02	.863	21.92	.768	19.51	.800	20.32	.865	21.97	

2M804 Push-Pull Hermetic Receptacle

Ordering Guide for 2M804-006

2M804 Series of Hermetic Receptacles:

2M804 Series of Hermetic Receptacles provide superior sealing of 1×10^{-6} cc/second helium leak rate and are 100% tested prior to shipping. This superior sealing is accomplished through the use of glass insulator fused to stainless steel shells and iron alloy contacts.

2M804 FEATURES INCLUDE:

- Low profile shells for minimum box protrusion
- Shell Standoff's for PC Board washout
- Non-removable PC and/or Soldercup contacts
- Hermetic Sealing

Series	Shell Style	Service Class	Shell Size-Insert Arrg.	Contact Type	Alternate Position	For single master key omit (leave blank)
2M804-006	-07	Z1	9-19	P	A	

SERIES	
2M804-006	Hermetic Receptacle with Printed Circuit Board Contacts or Solder Cup Contacts.

SHELL STYLE	
-00	Jam Nut for Front Panel Mounting
-07	Jam Nut for Rear Panel Mounting

SERVICE CLASS		
		Finish
ZL		Stainless Steel/ Nickel Plated
Z1		Stainless Steel/Passivated

SHELL SIZE - INSERT ARRANGEMENTS	
See Insert Arrangements on Pages 7-9	

CONTACTS	
P	Pin, Solder Cup
C	Pin, PC Tail

KEYING		
Key Position	Key Rotation	
	A	B
A (Normal)	150°	210°
B	75°	210°
C	95°	230°
D	140°	275°

Receptacle View

2M804

2M804-006-07

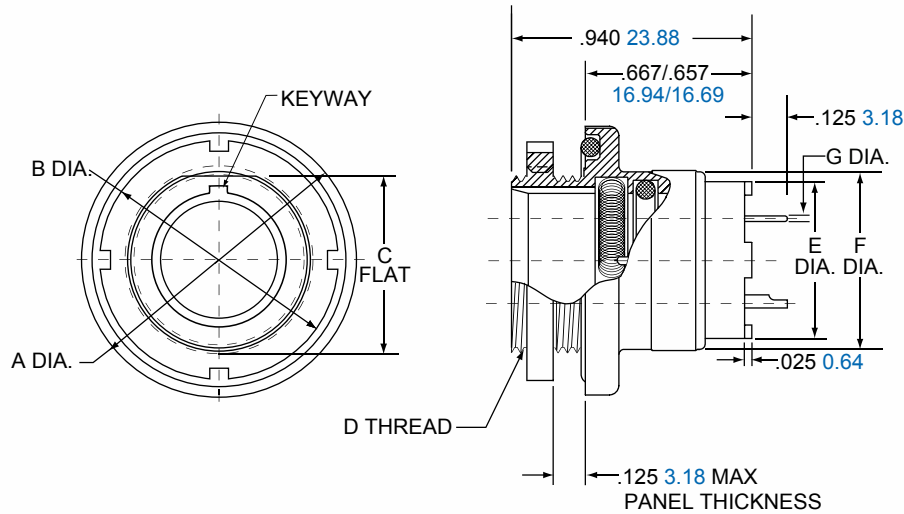

2M804

Shell Size	A Dia.		B Dia.		C Flat		D Threads	E Dia.		F Dia.		G PC Tail Dia.
	in.	mm.	in.	mm.	in.	mm.		in.	mm.	in.	mm.	
5	.790	20.07	.562	14.27	.415	10.54	.4375-32 UN-2A	.244	6.20	.450	11.43	#23 .018/.022 0.46/0.56
6	.830	21.08	.625	15.87	.467	14.40	.5000-32 UN-2A	.330	8.38	.520	13.21	
7	.910	23.11	.750	19.05	.594	15.09	.6250-28 UN-2A	.432	10.97	.580	14.73	#20 .024/.028 0.61/0.71
8	.955	24.26	.750	19.05	.594	15.09	.6250-28 UN-2A	.493	12.52	.603	15.32	
9	1.000	25.40	.812	20.62	.655	16.64	.6875-28 UN-2A	.551	14.00	.695	17.65	#16 .060/.064 1.52/1.63
10	1.085	27.48	.875	22.22	.721	18.31	.7500-28 UN-2A	.620	15.75	.735	18.67	
12	1.180	29.97	1.000	25.40	.843	21.41	.8750-28 UN-2A	.703	17.86	.880	22.35	#12 .092/.096 2.34/2.44
14	1.325	33.66	1.125	28.57	.968	24.59	1.0000-28 UN-2A	.863	21.92	1.010	25.65	

JAM NUT PANEL CUTOUT

Shell Size	A Flat		B Dia.	
	in. ±.002	mm. ± 0.05	in. ±.005	mm. ± 0.13
5	.423	10.74	.448	11.38
6	.475	12.07	.510	12.95
7	.588	14.94	.635	16.13
8	.602	15.29	.635	16.13
9	.663	16.84	.698	17.73
10	.729	18.82	.760	19.30
12	.851	21.62	.885	22.48
14	.976	24.79	1.010	25.65

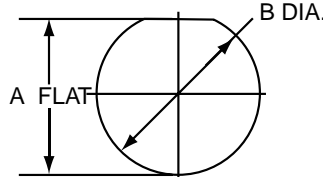

2M804 Push-Pull Front Panel Jam Nut Hermetic

2M804-006-00

2M804-006-00

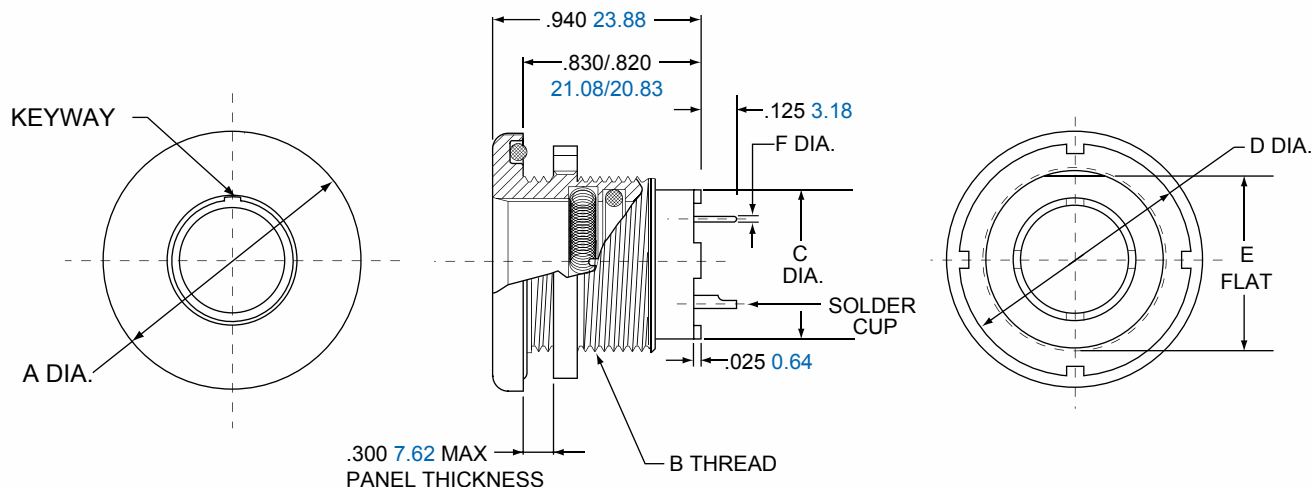

Shell Size	A Dia.		B Thread	C Dia.		D Dia.		E Flat.		F PC Tail Dia.
	in.	mm		in.	mm.	in.	mm.	in.	mm.	
5	.830	21.08	.5000-32 UN-2A	.244	6.20	.625	15.87	.470	11.94	#23 .018/.022 0.46/0.56
6	.885	22.48	.6250-28 UN-2A	.330	8.38	.688	17.47	.530	13.46	#20 .024/.028 0.61/0.71
7	.995	25.27	.6250-28 UN-2A	.432	10.97	.812	20.62	.663	16.84	#16 .060/.064 1.52/1.63
8	.995	25.27	.6875-28 UN-2A	.493	12.52	.812	20.62	.663	16.84	#12 .092/.096 2.34/2.44
9	1.075	27.31	.7500-28 UN-2A	.551	14.00	.875	22.22	.720	18.29	
10	1.140	28.95	.8750-28 UN-2A	.620	15.75	.938	23.82	.788	20.02	
12	1.340	34.04	1.0000-28 UN-2A	.703	17.86	1.125	28.57	.970	24.64	
14	1.390	35.31	1.0625-20 UN-2A	.863	21.92	1.188	30.18	1.020	25.91	

JAM NUT PANEL CUTOUT

Shell Size	A Flat		B Dia.	
	in. ±.002	mm. ± 0.05	in. ±.005	mm. ± 0.13
5	.423	10.74	.448	11.38
6	.475	12.07	.510	12.95
7	.588	14.94	.635	16.13
8	.602	15.29	.635	16.13
9	.663	16.84	.698	17.73
10	.729	18.82	.760	19.30
12	.851	21.62	.885	22.48
14	.976	24.79	1.010	25.65

Diagram of the jam nut panel cutout showing dimensions A FLAT and B DIA.

2M804

Series	Service Class	Shell Size	Attachment Type	Attachment Code	Attachment Length in Inches	Pull Ring Option
2M667-202	-M	9	-G	04	-5	R

SERIES	
2M667-202	Protection Caps 2M804 Receptacles





SHELL SIZE
5
6
7
8
9
10
12
14

ATTACHMENT TYPE	
-G	Nylon Rope
-H	Stainless Steel Wire Rope, Teflon® Jacket
-N	No Attachment
-S	Stainless Steel Sash Chain
-SK	Nylon Rope With Slip Knot
-T	Stainless Steel Wire Rope, No Jacket
-U	Stainless Steel Wire Rope, Polyurethane Jacket

Omit for attachment Type N (No Attachment)
Example "-5" equals five inch length

PULL RING OPTIONS	
R	Supplied with Pull Ring
	Omit for None

ATTACHMENT CODE	
Omit for attachment Types N (No Attachment) and SK (Slip Knot)	
Small Ring	01 – 126 (3.20) I.D. 02 – 145 (3.68) I.D. 04 – 188 (4.78) I.D. 06 – 197 (5.00) I.D.
Large Ring	14 – 385 (9.78) I.D. 15 – 445 (11.30) I.D. 16 – 570 (14.48) I.D. 17 – 635 (16.13) I.D. 18 – 695 (17.65) I.D. 19 – 885 (22.48) I.D. 20 – 1.070 (27.17) I.D. 21 – 1.135 (28.83) I.D. 25 – 0.820 (20.8) I.D.
Split Ring	50 – 420 (10.67) I.D. 52 – 480 (12.19) I.D. 54 – 635 (16.13) I.D. 56 – 745 (18.92) I.D. 58 – 885 (22.48) I.D. 60 – 1.010 (25.65) I.D. 64 – 1.125 (28.58) I.D. 68 – 1.345 (34.16) I.D.

SERVICE CLASS		
		Finish
C		Aluminum/Black Anodize (Non-Conductive)
M		Aluminum/Electroless Nickel
NF		Aluminum/Cadmium with Olive Drab Chromate
MT		Aluminum/Nickel-PTFE (Duralon)
Z1		Stainless Steel/Passivated
ZN		Aluminum/Zinc-Nickel w/Olive Drab Chromate
ZNU		Aluminum/Zinc-Nickel with Black Chromate



2M804

2M804 Push-Pull Plug Protection Caps

Ordering Guide for 2M809-198

Series	Service Class	Shell Size	Attachment Type	Attachment Code	Attachment Length in Inches	Shell Key Position
2M809-198	-M	6	-G	04	-5	

For single master key omit (leave blank)

SERIES	
2M809-198	Protection Cap for 2M804 Plug

SHELL SIZE
5
6
7
8
9
10
12
14

ATTACHMENT TYPE	
-G	Nylon Rope
-H	Stainless Steel Wire Rope, Teflon® Jacket
-N	No Attachment
-S	Stainless Steel Sash Chain
-SK	Nylon Rope With Slip Knot
-T	Stainless Steel Wire Rope, No Jacket
-U	Stainless Steel Wire Rope, Polyurethane Jacket

Omit for attachment Type N (No Attachment)
Example "-5" equals five inch length

SERVICE CLASS		
		Finish
C		Aluminum/Black Anodize (Non-Conductive)
M		Aluminum/Electroless Nickel
NF		Aluminum/Cadmium with Olive Drab Chromate
MT		Aluminum/Nickel-PTFE (Durmalon)
Z1		Stainless Steel/Passivated
ZN		Aluminum/Zinc-Nickel w/Olive Drab Chromate
ZNU		Aluminum/Zinc-Nickel with Black Chromate

ATTACHMENT CODE	
Omit for attachment Types N (No Attachment) and SK (Slip Knot)	
Small Ring	01 - .126 (3.20) I.D.
	02 - .145 (3.68) I.D.
	04 - .188 (4.78) I.D.
	06 - .197 (5.00) I.D.
	14 - .385 (9.78) I.D.
	15 - .445 (11.30) I.D.
Large Ring	16 - .570 (14.48) I.D.
	17 - .635 (16.13) I.D.
	18 - .695 (17.65) I.D.
	19 - .885 (22.48) I.D.
	20 - 1.070 (27.17) I.D.
	21 - 1.135 (28.83) I.D.
	22 - 1.210 (30.73) I.D.
	23 - 1.275 (32.39) I.D.
	24 - 1.375 (34.94) I.D.
	24 - 0.820 (20.8) I.D.
Split Ring	50 - .420 (10.67) I.D.
	52 - .480 (12.19) I.D.
	54 - .635 (16.13) I.D.
	56 - .745 (18.92) I.D.
	58 - .885 (22.48) I.D.
	60 - 1.010 (25.65) I.D.
	64 - 1.125 (28.58) I.D.
	68 - 1.345 (34.16) I.D.

KEYING		
Key Position	Key Rotation	
	A	B
A (Normal)	150°	210°
B	75°	210°
C	95°	230°
D	140°	275°

Plug View

2M804



2M804 Push-Pull Protection Cap

Metal Protection Cap 2M809-198 and 2M667-202

2M809-198

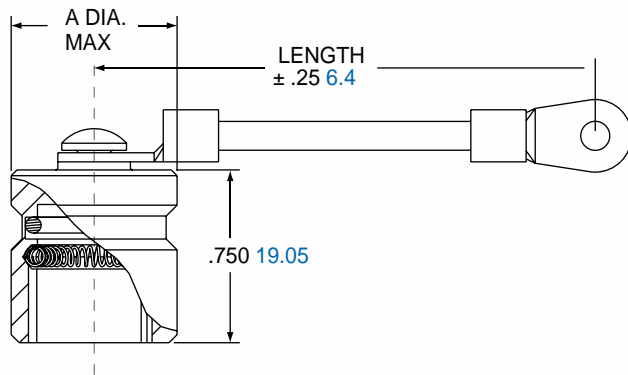

2M667-202

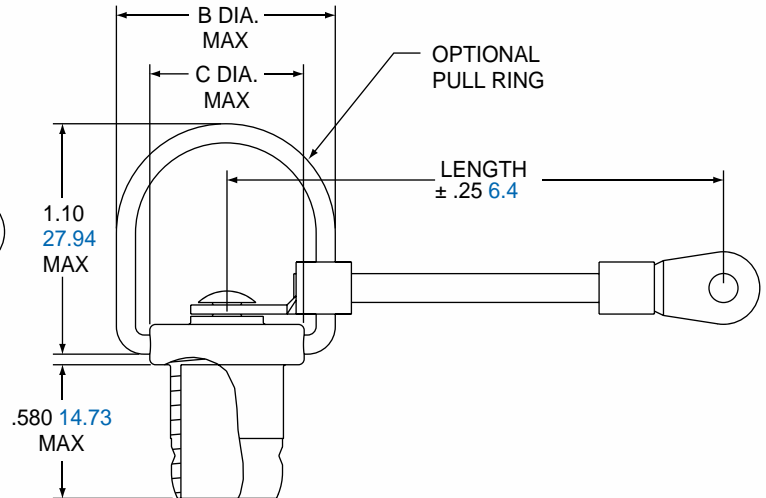



2M804

Shell Size	A Max.		B Max.		C Max.	
	in.	mm.	in.	mm.	in.	mm.
5	.496	12.60	.740	18.80	.490	12.45
6	.540	13.72	.740	18.80	.490	12.45
7	.645	16.38	.820	20.83	.570	14.48
8	.665	16.89	.870	22.10	.619	15.72
9	.720	18.29	.920	23.37	.670	17.02
10	.790	20.07	1.030	26.16	.783	19.89
12	.915	23.24	1.110	28.19	.860	21.84
14	1.040	26.42	1.230	31.24	.980	24.89

MATERIALS AND FINISHES

Cover	Aluminum alloy or stainless steel
O-Ring	Fluorosilicone rubber
Wire, Hardware	Stainless steel, passivated

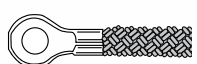
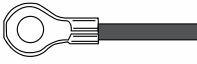
LANYARD OPTIONS

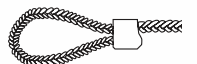
	Nylon Rope	-55° to +100°C., black, flexible, good abrasion resistance, good resistance to fuels, .120" 3mm diameter
	Polyurethane Coated Wire Rope	Black polyurethane over stainless steel rope, very flexible, excellent abrasion resistance, excellent resistance to fuels, .080" 2mm diameter
	Teflon® Jacketed Wire Rope	Translucent FEP jacket over stainless steel, -55° to +200°C., fair flexibility, good abrasion resistance, .100" diameter
	Sash Chain	Stainless steel
	Slip Knot (SK) for attaching Covers to Cables	55° to +100°C., black, flexible, good abrasion resistance, good resistance to fuels, .120" 3mm diameter. Length includes .5" 13mm diameter loop.

2M804 Push-Pull Plug Rubber Caps

Ordering Guide for 2M809-083 and 2M809-087



2M804

Series	Shell Size	Lanyard Length	Attachment Code	Conductive Rubber
2M809-083	6	5	04	C

Example "-5" equals five inch length

SERIES	
2M809-083	Protection Cap for 2M804 Plugs
2M809-087	Protection Cap for 2M804 Receptacles

SHELL SIZE
5
6
7
8
9
10
12
14

ATTACHMENT CODE	
-WS	Nylon Cable tie, 1.77 Inch (45mm) Maximum Wire Bundle Diameter
-SK	Slip Knot
-00	Lanyard with no attachment (fused End)
-01	-.126 (3.20) I.D.
-02	-.145 (3.68) I.D.
-04	-.188 (4.78) I.D.
-06	-.197 (5.00) I.D.
-07	-.385 (9.78) I.D.
-08	-.510 (13.11) I.D.
-09	-.583 (14.81) I.D.
-10	-.766 (19.4) I.D.
-11	-.896 (25.76) I.D.
-12	-1.015 (25.78) I.D.
-15	-.445 (11.30) I.D.
-16	-.570 (14.48) I.D.
-17	-.635 (16.13) I.D.
-18	-.695 (17.65) I.D.
-19	-.885 (22.48) I.D.
-20	-1.070 (27.18) I.D.
-21	-1.135 (28.83) I.D.
-25	-0.820 (20.8) I.D.

CONDUCTIVE RUBBER	
Omit for Standard Neoprene	
C	Conductive Rubber

2M804 Push-Pull Plug Rubber Caps

Rubber Caps 2M809-083 and 2M809-087

2M804

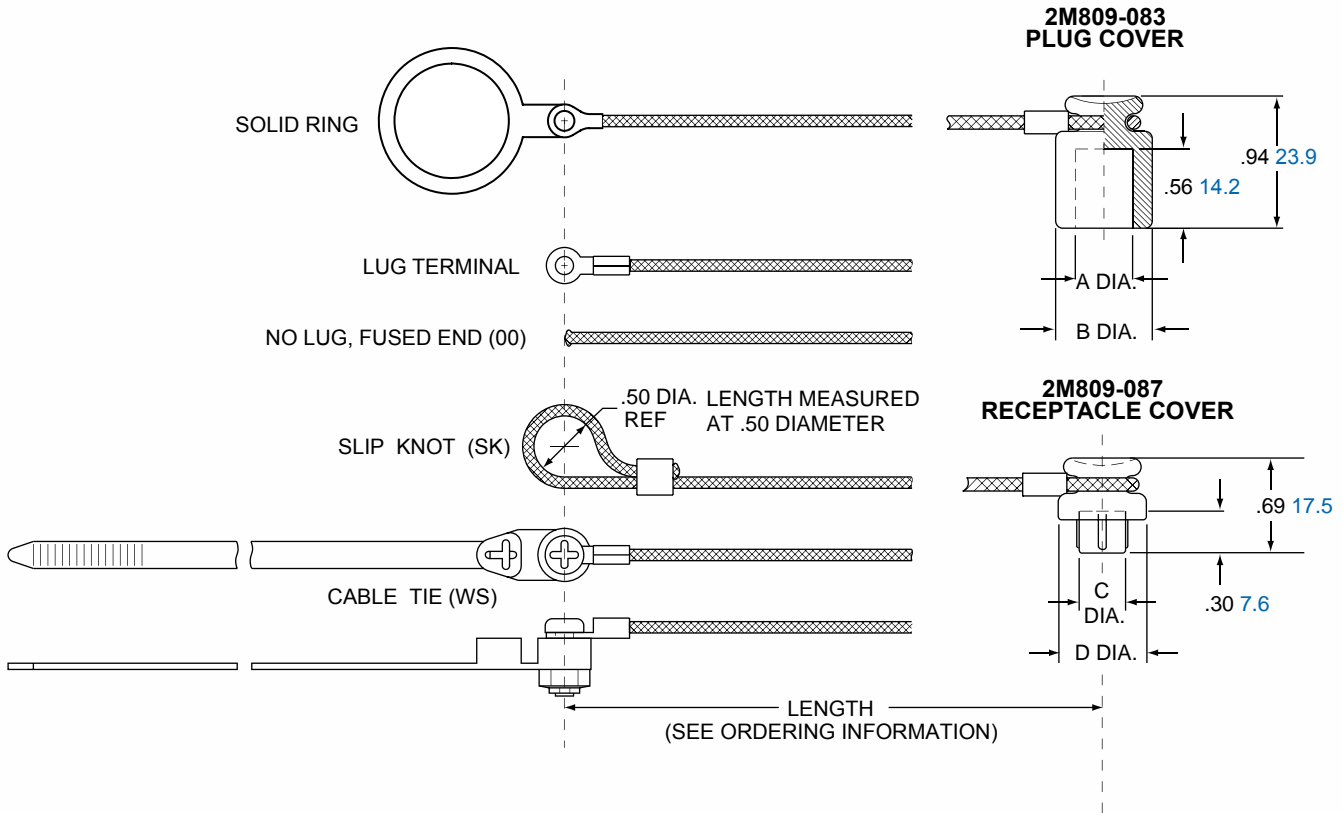

Shell Size	A Dia.		B Dia.		C Dia.		D Dia.	
	in.	mm.	in. ± .005	mm. ± 0.13	in.	mm.	in.	mm.
5	.23	5.8	.56	14.2	.27	6.9	.59	15.0
6	.29	7.4	.56	14.2	.33	8.4	.65	16.5
7	.36	9.1	.56	14.2	.40	10.2	.78	19.8
8	.41	10.4	.68	17.3	.44	11.2	.78	19.8
9	.46	11.7	.68	17.3	.50	12.7	.84	21.3
10	.54	13.7	.79	20.1	.57	14.5	.90	22.9
12	.55	14.0	.79	20.1	.69	17.5	1.03	26.2
14	.78	19.8	1.11	28.2	.82	20.8	1.15	29.2

MATERIALS

Cover	Neoprene rubber blend, black
Lanyard	.062" (1.57) diameter nylon cord, black
Cable Tie	6/6 nylon, black SST locking tab
Ring	Stainless steel, black zinc-cobalt finish

General Information

2M805 Series Micro Miniature Connectors:

Amphenol's 2M805 Series of connectors offers the best EMI and Vibration performance among all the 2M connector series. The series features a Tri-Start thread with 1 turn full mate coupling. An EMI ground strap and shell-to-shell bottoming provide superior EMI shielding. Plugs and Receptacles are provided in two different styles to accommodate the attachment of backshell with rear accessory threads or with integral backshell. The integral backshell allows for use of EMI shielding attachments and/or overmolding. Contact termination styles include Crimp, PC Tail, and Solder cup with others available upon request. Custom and Filter configuration are available, please consult factory for ordering information.

2M805 FEATURES INCLUDE:

- Anti-Vibration Self locking Plugs
- Tri-Start thread for 1 turn full mating
- Superior EMI shielding
- Sealed Receptacles:
 - Hermetic (1×10^{-6} cc/second)
 - Epoxy Backfilled (1×10^{-4} cc/second)
- ROHS Compliant Plating
- Insert Arrangements up to 130 contacts



2M805

2M805 SPECIFICATIONS

Current Rating	See Insert Arrangements (p.7-9)
DWV	See Insert Arrangements (p.7-9)
Insulation Resistance	5000 megohms min.
Operating Temperature	-65° C to +150° C
Shock	300 g's
Random Vibration	37 g's
Shielding Effectiveness	65 dB min. from 100MHz to 1000MHz
Durability	500 mating cycles

2M805 MATERIALS AND FINISHES

Shells	Aluminum Alloy or Stainless Steel
Contacts	Copper Alloy, gold plated
Insulators	Polyphenylene Sulfide (PPS)
Contact Retention	Beryllium Copper Alloy
Grommet, Interfacial Seal, O'Ring	Fluorosilicone Rubber

SERIES 2M805 CONNECTOR WEIGHT IN GRAMS

Insert Arrangements	Cable Plug	J/N Recept. Crimp	J/N Recep. PCB	Sq. Flange Recept. Crimp	Sq. Flange Recept. PDB
8-1P	7.5	5.8	5.7	5.8	4.6
8-1S	7.9	6.3	6.2	6.3	5.1
8-4P	8.3	6.6	6.5	6.6	5.4
8-4S	8.8	7.2	7.0	7.2	5.9
8-7P	7.3	5.6	5.5	5.6	4.4
8-7S	7.7	6.1	5.9	6.1	4.8
9-1P	10.9	9.0	9.0	6.8	7.7
9-1S	11.4	9.6	9.6	7.4	8.3
9-10P	10.7	8.8	8.8	6.6	7.5
9-10S	11.6	9.7	9.7	7.5	8.4
10-2P	13.3	10.2	10.3	8.9	9.4
10-2S	14.1	11.0	11.1	9.7	10.1
10-13P	12.7	9.6	9.7	8.3	8.7
10-13S	13.4	10.3	10.5	9.0	9.5
10-200P	13.9	10.8	10.9	9.5	9.9
10-200S	14.7	11.7	11.8	10.3	10.8
11-4P	15.4	12.1	13.1	10.3	11.3
11-4S	16.4	13.1	14.1	11.3	12.3
11-19P	14.3	11.0	12.0	9.2	10.2
11-19S	15.4	12.1	13.1	10.3	11.3
11-200P	14.9	11.6	12.5	9.8	10.8
11-200S	16.0	12.7	13.6	10.9	11.9
11-201P	15.4	12.1	13.1	10.3	11.3
11-201S	16.6	13.3	14.3	11.6	12.5
12-5P	17.6	13.9	16.3	12.2	13.1
12-5S	19.0	15.3	17.7	13.6	14.5
12-26P	15.8	12.1	14.5	10.5	11.3
12-26S	17.4	13.6	16.1	12.0	12.9
12-200P	16.5	12.8	15.2	11.1	12.0
12-200S	17.9	14.2	16.6	12.5	13.4
12-201P	16.6	12.9	15.3	11.2	12.1
12-201S	18.0	14.3	16.7	12.7	13.5

SERIES 2M805 CONNECTOR WEIGHT IN GRAMS

Insert Arrangements	Cable Plug	J/N Recept. Crimp	J/N Recep. PCB	Sq. Flange Recept. Crimp	Sq. Flange Recept. PDB
12-202P	16.6	12.9	15.3	11.2	12.1
12-202S	18.2	14.4	16.8	12.8	13.6
15-2P	20.7	20.2	21.8	17.1	19.5
15-2S	22.3	21.9	23.4	18.7	21.1
15-3P	21.7	21.2	22.8	18.0	20.5
15-3S	23.4	23.0	24.5	19.8	22.2
15-7P	21.9	21.5	23.0	18.3	20.7
15-7S	24.5	24.1	25.6	20.9	23.3
15-37P	20.1	19.7	21.2	16.5	18.9
15-37S	23.0	22.6	24.1	19.4	21.8
15-200P	20.4	19.9	21.5	16.7	19.1
15-200S	22.6	22.1	23.7	18.9	21.3
15-201P	20.7	20.2	21.8	17.1	19.5
15-201S	23.0	22.6	24.1	19.4	21.8
18-5P	29.9	31.6	30.1	26.1	29.0
18-5S	32.9	34.5	33.1	29.0	32.0
18-12P	30.7	32.3	30.9	26.8	29.8
18-12S	34.3	36.0	34.5	30.5	33.4
18-55P	27.3	28.9	27.5	23.4	26.4
18-55S	30.7	32.3	30.9	26.8	29.8
19-7P	27.9	30.0	33.1	25.1	33.0
19-7S	31.0	33.1	36.2	28.2	36.1
19-14P	32.9	35.0	38.1	30.0	38.0
19-14S	32.6	34.7	37.7	29.7	37.6
19-85P	26.6	28.7	31.8	23.8	31.7
19-85S	31.1	33.2	36.3	28.3	36.2
23-17P	40.2	42.9	44.4	36.7	43.9
23-12S	45.2	48.0	49.5	41.8	49.0
23-22P	42.7	45.4	47.0	39.3	46.4
23-22S	49.6	52.4	53.9	46.2	53.4
23-130P	37.8	40.6	42.1	34.4	41.6
23-130S	44.9	47.7	49.3	41.6	48.7

2M805

2M805 Tri-Start Threaded Coupling

Ordering Guide for 2M805 Plug & Receptacle

Series 2M805 Connector

Series	Shell Style	Service Class	Shell Size-Insert Arrg.	Contact Type	Alternate Position
2M805-00	-16	C	15-37	S	A

SERIES	
2M805-001	Plug with Integral Backshell
2M805-002	Plug with Accessory Thread
2M805-003	Receptacle with Integral Backshell
2M805-004	Receptacle with Accessory Thread

SHELL SIZE - INSERT ARRANGEMENTS

See Insert Arrangements on Pages 8-10



CONTACTS

P	Pin Contacts
S	Socket Contacts

SHELL STYLE 2M805-001, 2M805-002	
-16	Plug Connector with Ratcheting Anti-Decoupling Mechanism

SHELL STYLE 2M805-003, 2M805-004	
-01	In-Line Receptacle
-02	Square Flange Receptacle
-07	Jam Nut for Rear Panel Mounting Receptacle

SERVICE CLASS	
	Finish
C	Aluminum/Black Anodize (Non-Conductive)
M	Aluminum/Electroless Nickel
NF	Aluminum/Cadmium with Olive Drab Chromate
MT	Aluminum/Nickel-PTFE (Duralon)
Z1	Stainless Steel/Passivated
ZN	Aluminum/Zinc-Nickel w/Olive Drab Chromate
ZNU	Aluminum/Zinc-Nickel with Black Chromate

KEYING		
Key Position	Key Rotation	
	A	B
Normal A	150°	210°
B	75°	210°
C	95°	230°
D	140°	275°

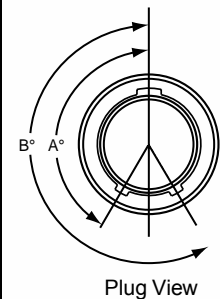
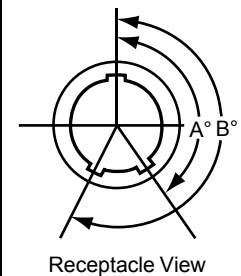

INSERT ARRANGEMENTS

Insert Arr.	No. of Contacts				
	#23	#20	#20HD	#16	#12
8-1				1	
8-4	4				
8-6	6				
8-7	7				
8-23			3		
9-1					1
9-10	10				
9-25			5		
10-2				2	
10-13	13				
10-28			8		
10-200	4	2			
11-4				4	
11-19	19				
11-200	4			2	
11-201	8	2			
11-210			10		
12-2					2
12-5				5	
12-26	26				
12-200	12				1

INSERT ARRANGEMENTS

Insert Arr.	No. of Contacts				
	#23	#20	#20HD	#16	#12
12-201	4				2
12-202	8			2	
15-2					2
15-3					3
15-7				7	
15-37	37				
15-200	6				2
15-201	10				2
15-220			20		
18-5					5
18-12				12	
18-55	55				
18-235			35		
19-7					7
19-14				14	
19-85	85				
19-241			41		
23-12					12
23-22				22	
23-130	130				
23-269			69		

2M805

2M805 Tri-Start Plug

2M805-001 and 2M805-002

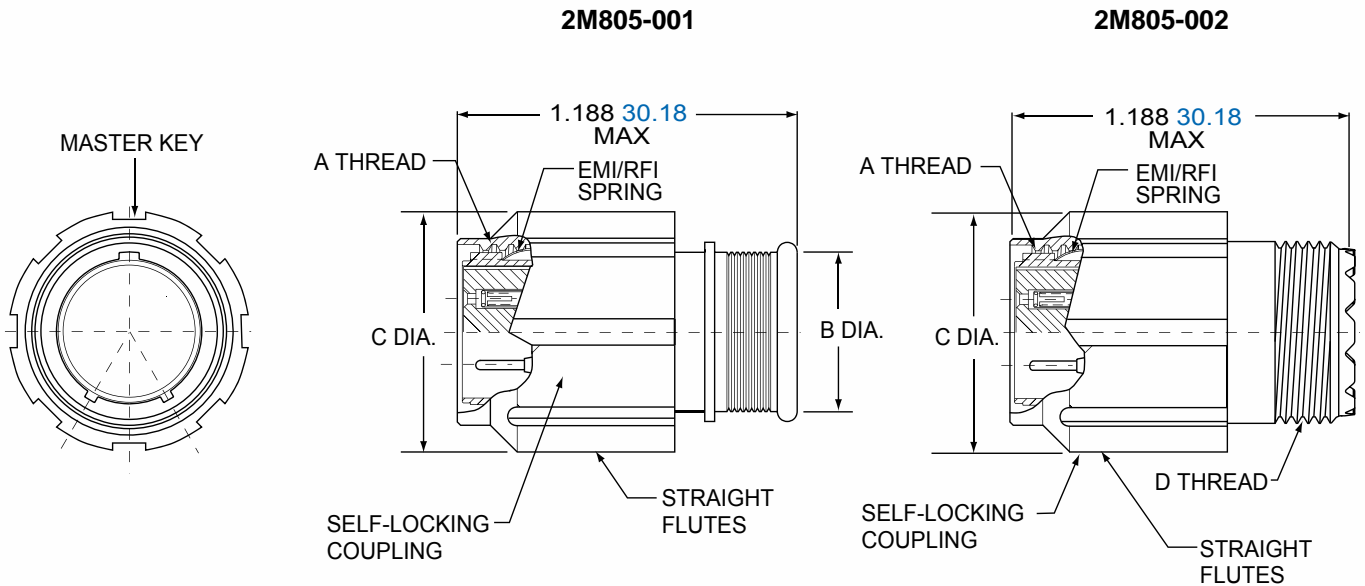

2M805

Shell Size	A Threads	B Dia.		C Dia.		D Threads Accessory
		in.	mm.	in.	mm.	
8	.5000.1P-.3L-TS-2B	.317	8.05	.691	17.55	.3750-32 UNEF-2A
9	.5625.1P-.3L-TS-2B	.397	10.08	.787	19.99	.4375-28 UNEF-2A
10	.6250.1P-.3L-TS-2B	.473	12.01	.826	20.98	.5000-28 UNEF-2A
11	.6875.1P-.3L-TS-2B	.519	13.18	.916	23.27	.5625-24 UNEF-2A
12	.7500.1P-.3L-TS-2B	.585	14.86	.982	24.94	.6250-24 UNEF-2A
15	.9375.1P-.3L-TS-2B	.687	17.45	1.097	27.86	.7500-20 UNEF-2A
18	1.1250.1P-.3L-TS-2B	.884	22.45	1.290	32.77	.9375-20 UNEF-2A
19	1.1875.1P-.3L-TS-2B	.884	22.45	1.310	33.27	.9375-20 UNEF-2A
23	1.4375.1P-.3L-TS-2B	1.135	28.83	1.562	39.67	1.1875-18 UNEF-2A

2M805 Tri-Start In-Line Receptacle

2M805-003-01 and 2M805-004-01

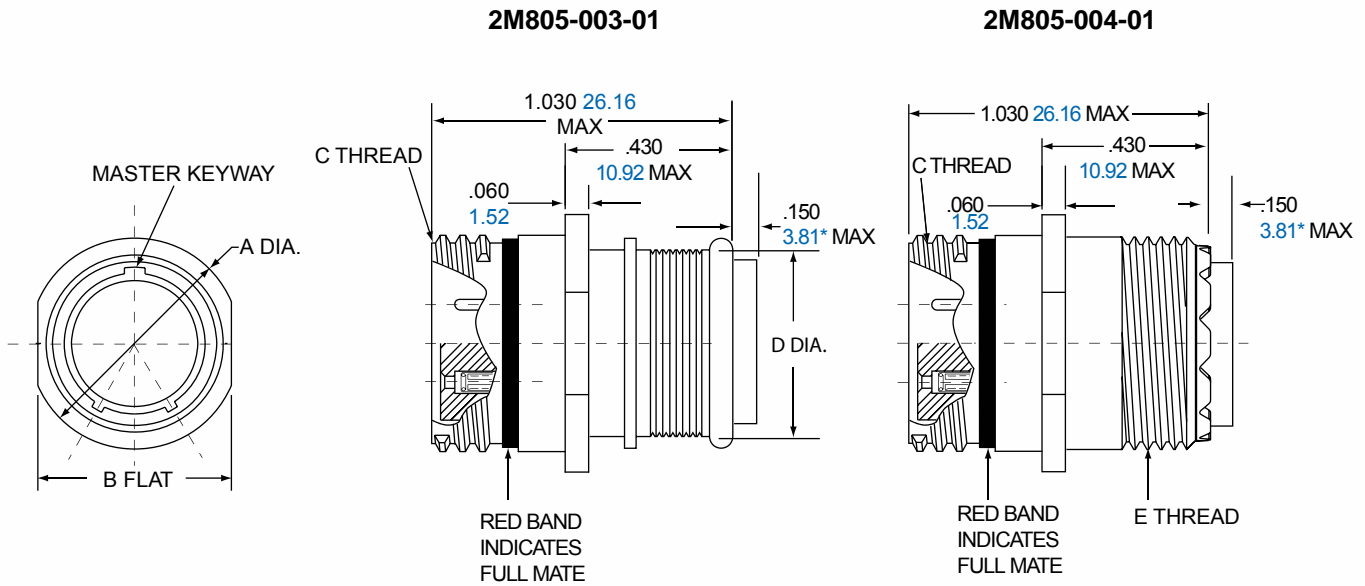

2M805

Shell Size	A Dia.		B Flat		C Threads	D Dia.		E Threads Accessory
	in.	mm.	in.	mm.		in.	mm.	
8	.540	13.72	.510	12.95	.5000.1P-.3L-TS-2A	.316	8.05	.3750-32 UNEF-2A
9	.605	15.37	.575	14.61	.5625.1P-.3L-TS-2A	.397	10.08	.4375-28 UNEF-2A
10	.668	16.96	.638	16.21	.6250.1P-.3L-TS-2A	.472	12.01	.5000-28 UNEF-2A
11	.730	18.54	.700	17.78	.6875.1P-.3L-TS-2A	.519	13.18	.5625-24 UNEF-2A
12	.793	20.14	.763	19.38	.7500.1P-.3L-TS-2A	.585	14.86	.6250-24 UNEF-2A
15	.980	24.89	.950	24.13	.9375.1P-.3L-TS-2A	.687	17.45	.7500-20 UNEF-2A
18	1.165	29.59	1.135	28.83	1.1250.1P-.3L-TS-2A	.884	22.45	.9375-20 UNEF-2A
19	1.235	31.37	1.205	30.61	1.1875.1P-.3L-TS-2A	.884	22.45	.9375-20 UNEF-2A
23	1.485	37.72	1.455	39.96	1.4375.1P-.3L-TS-2A	1.134	28.80	1.1875-18 UNEF-2A

2M805 Tri-Start Square Flange Receptacle

2M805-003-02 and 2M805-004-02

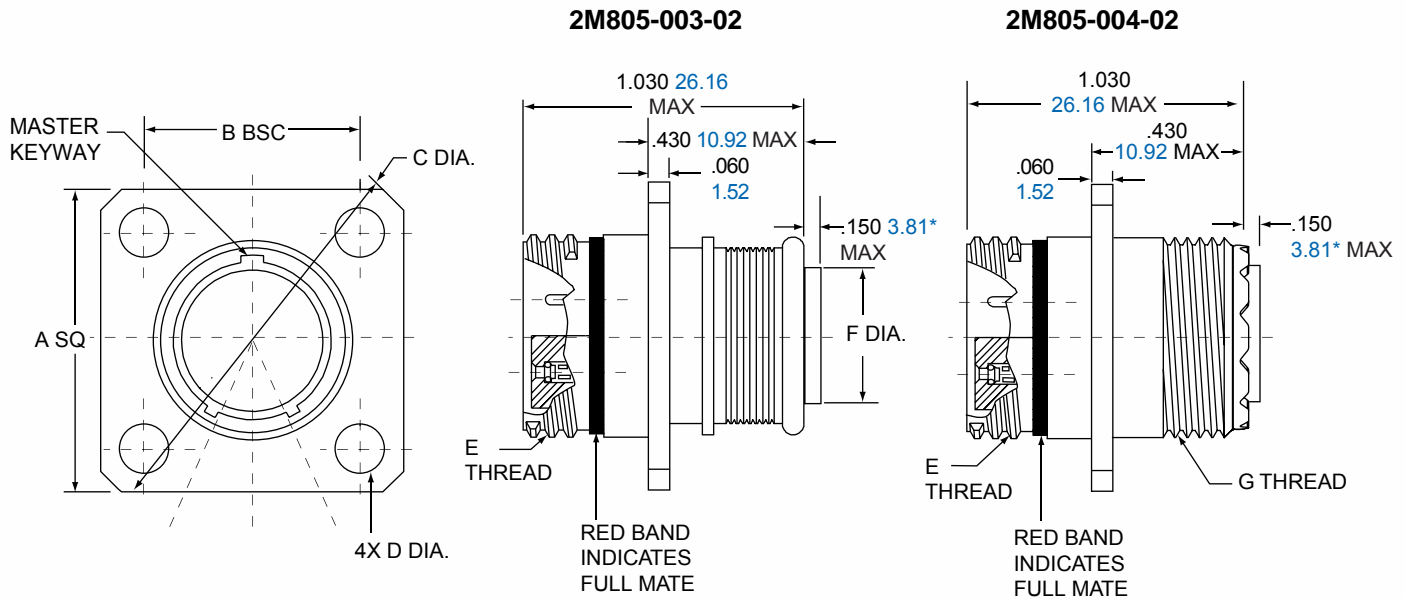

2M805

Shell Size	A Sq.		B BSC.		C Dia.		D Dia.		E Threads	F Dia.		G Threads Accessory
	in.	mm.	in.	mm.	in.	mm.	in. ±.003	mm. ±.08		in.	mm.	
8	.850	21.59	.660	16.76	1.150	29.21	.094	2.39	.5000 .1P-.3L-TS-2A	.316	8.05	.3750-32 UNEF-2A
9	.913	23.19	.723	18.36	1.230	31.24	.094	2.39	.5625.1P-.3L-TS-2A	.397	10.08	.4375-28 UNEF-2A
10	.975	24.77	.785	19.94	1.330	33.78	.094	2.39	.6250.1P-.3L-TS-2A	.472	12.01	.5000-28 UNEF-2A
11	1.039	26.39	.848	21.54	1.410	35.81	.094	2.39	.6875.1P-.3L-TS-2A	.519	13.18	.5625-24 UNEF-2A
12	1.099	27.91	.909	23.09	1.500	38.10	.094	2.39	.7500.1P-.3L-TS-2A	.585	14.86	.6250-24 UNEF-2A
15	1.288	32.74	1.058	26.87	1.750	44.45	.128	3.25	.9375.1P-.3L-TS-2A	.687	17.45	.7500-20 UNEF-2A
18	1.475	37.47	1.255	31.88	2.000	50.80	.128	3.25	1.1250.1P-.3L-TS-2A	.884	22.45	.9375-20 UNEF-2A
19	1.537	71.06	1.327	33.71	2.094	53.19	.128	3.25	1.1875.1P-.3L-TS-2A	.884	22.45	.9375-20 UNEF-2A
23	1.787	45.39	1.570	39.88	2.440	61.98	.128	3.25	1.4375.1P-.3L-TS-2A	1.134	28.80	1.1875-18 UNEF-2A

2M805 Tri-Start Jam Nut Receptacle

2M805-003-07 and 2M805-004-07

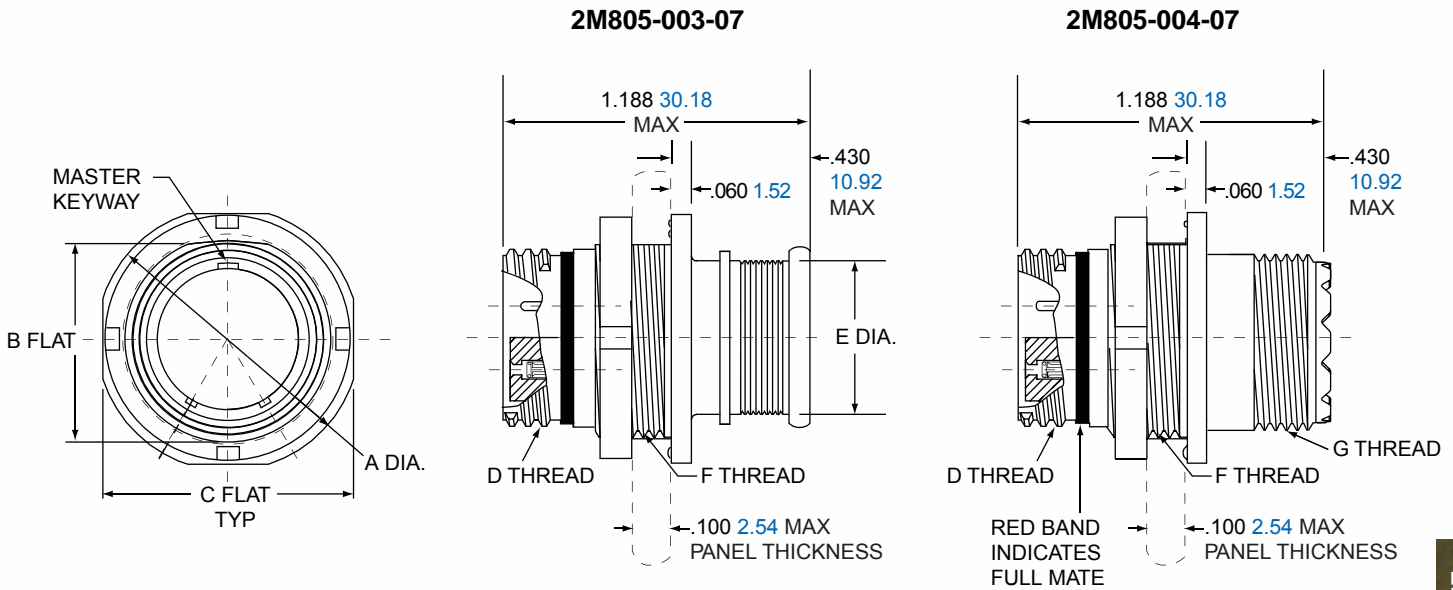

2M805

Shell Size	A Dia.		B Flat		C Flat		D Threads	E Dia.		F Threads	G Threads Accessory
	in.	mm.	in.	mm.	in.	mm.		in.	mm.		
8	.760	19.30	.535	13.59	.730	18.54	.5000.1P-.3L-TS-2A	.317	8.05	.5625-28 UNEF-2A	.3750-32 UNEF-2A
9	.880	22.35	.661	16.79	.850	21.59	.5625.1P-.3L-TS-2A	.397	10.08	.6875-28 UN-2A	.4375-28 UNEF-2A
10	.880	22.35	.661	16.79	.850	21.59	.6250.1P-.3L-TS-2A	.473	12.01	.6875-28 UN-2A	.5000-28 UNEF-2A
11	.955	24.26	.721	18.31	.925	23.50	.6875.1P-.3L-TS-2A	.519	13.18	.7500-28 UN-2A	.5625-24 UNEF-2A
12	1.060	26.92	.784	19.91	1.035	26.29	.7500.1P-.3L-TS-2A	.585	14.86	.8125-28 UN-2A	.6250-24 UNEF-2A
15	1.203	30.56	.970	24.64	1.173	29.79	.9375.1P-.3L-TS-2A	.687	17.45	1.0000-28 UN-2A	.7500-20 UNEF-2A
18	1.389	35.28	1.147	29.13	1.359	34.52	1.1250.1P-.3L-TS-2A	.884	22.45	1.1875-28 UN-2A	.9375-20 UNEF-2A
19	1.450	36.83	1.221	31.01	1.420	36.07	1.1875.1P-.3L-TS-2A	.884	22.45	1.2500-28 UN-2A	.9375-20 UNEF-2A
23	1.705	43.31	1.470	37.34	1.675	42.55	1.4375.1P-.3L-TS-2A	1.134	28.80	1.500-25 UN-2A	1.1875-18 UNEF-2A

PANEL CUTOUT FOR JAM NUT

Shell Size	A Flat		B Dia	
	in. ±.002	mm. ± 0.05	in. ±.005	mm. ± 0.13
8	.543	13.79	.572	14.53
9	.669	16.99	.698	17.73
10	.669	16.99	.698	17.73
11	.729	18.51	.760	19.30
12	.792	20.17	.822	20.88
15	.978	24.84	1.010	25.65
18	1.155	29.34	1.198	30.43
19	1.231	31.27	1.260	32.00
23	1.480	37.59	1.510	38.35

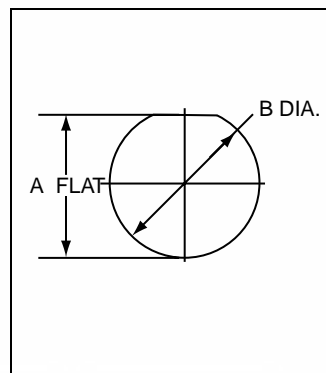

2M805 Series of PC Board Receptacles:

2M805 Series of PC Board Receptacles are intended for use of terminating the connector directly to a Circuit Board or Flex assembly. These connectors however can be supplied with solder cup termination for direct wire attachment.

2M805 FEATURES INCLUDE:

- Low profile shells for minimum box protrusion
- Shell Standoff's for PC Board washout
- Non-removable PC and/or Soldercup contacts
- Environmental Sealing

Series	Shell Style	Service Class	Shell Size-Insert Arrg.	Contact Type	Alternate Position
2M805-0XX	-02	C	15-37	S	A

SHELL SIZE - INSERT ARRANGEMENTS

See Insert Arrangements on Pages 7-9

CONTACTS

P	Pin, PC Tail
S	Socket, PC Tail
E	Pin, Solder Cup
F	Socket, Solder Cup

SERIES

2M805-005	Receptacle for Solder Cup or PCB Termination, with Standard Epoxy Potting
2M805-017	Receptacle for Solder Cup or PCB Termination with Special Sealing for open face (unmated) Water Immersion Requirements. 100% leak tested to maintain a helium leak rate of 1×10^{-4} cc/sec. at 1 atmosphere pressure differential from -40°C to 70°C

SHELL STYLE

-02	Square Flange Receptacle
-07	Jam Nut for Rear Panel Mounting Receptacle

SERVICE CLASS

	Finish
C	Aluminum/Black Anodize (Non-Conductive)
M	Aluminum/Electroless Nickel
NF	Aluminum/Cadmium with Olive Drab Chromate
MT	Aluminum/Nickel-PTFE (Durmalon)
Z1	Stainless Steel/Passivated
ZN	Aluminum/Zinc-Nickel w/Olive Drab Chromate
ZNU	Aluminum/Zinc-Nickel with Black Chromate

KEYING

Key Position	Key Rotation	
	A	B
(Normal) A	150°	210°
B	75°	210°
C	95°	230°
D	140°	275°

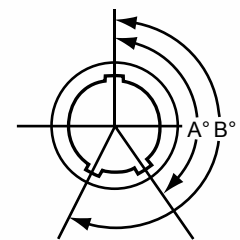

Receptacle View

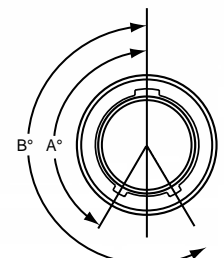

Plug View



2M805 Tri-Start PC Tail-Solder Cup Square Flange

2M805-005-02 and 2M805-017-02

2M805-005-02
2M805-017-02

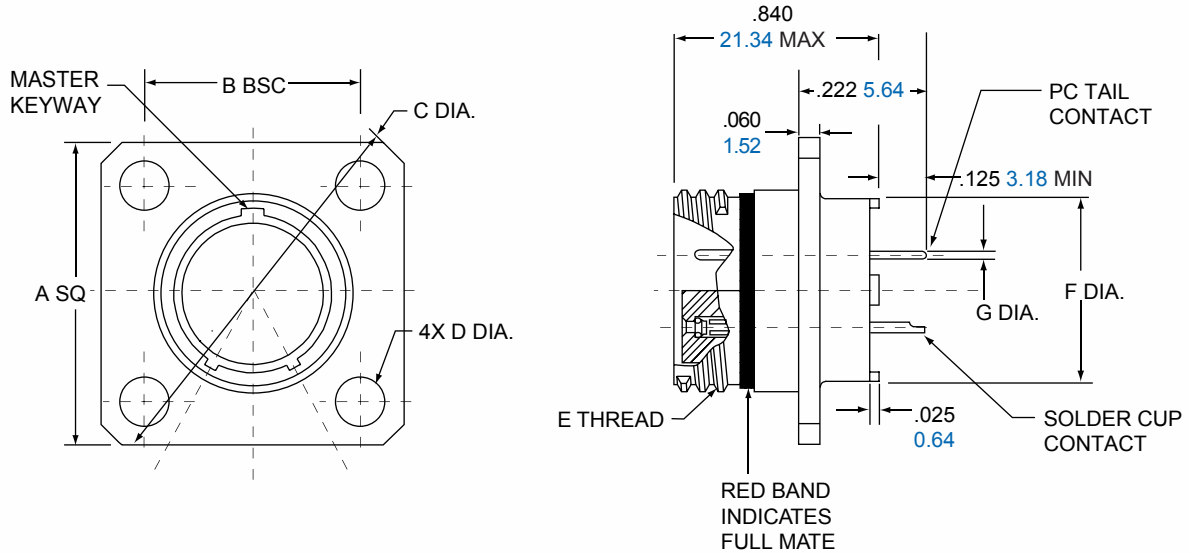

Shell Size	A Sq.		B BSC.		C Dia.		D Dia.		E Threads	F Dia.		G PC Tail Dia.
	in.	mm.	in.	mm.	in.	mm.	in. ±.003	mm. ±.08		in.	mm.	
8	.850	21.59	.660	16.76	1.150	29.21	.094	2.39	.5000.1P-.3L-TS-2A	.330	8.38	#23 .018/.022 0.46/0.56
9	.913	23.19	.723	18.36	1.230	31.24	.094	2.39	.5625.1P-.3L-TS-2A	.432	10.97	#20 .024/.028 0.61/0.71
10	.975	24.77	.785	19.94	1.330	33.78	.094	2.39	.6250.1P-.3L-TS-2A	.493	12.52	#16 .060/.064 1.521/1.63
11	1.039	26.39	.848	21.54	1.410	35.81	.094	2.39	.6875.1P-.3L-TS-2A	.551	14.00	#12 .092/.096 2.34/2.44
12	1.099	27.91	.909	23.09	1.500	38.10	.094	2.39	.7500.1P-.3L-TS-2A	.620	15.78	
15	1.288	32.74	1.058	26.87	1.750	44.45	.128	3.25	.9375.1P-.3L-TS-2A	.703	17.86	
18	1.475	37.47	1.255	31.88	2.000	50.80	.128	3.25	1.1250.1P-.3L-TS-2A	.863	21.92	
19	1.537	71.06	1.327	33.71	2.094	53.19	.128	3.25	1.1875.1P-.3L-TS-2A	.912	23.16	
23	1.787	45.39	1.570	39.88	2.440	61.98	.128	3.25	1.4375.1P-.3L-TS-2A	1.162	29.51	

2M805

2M805 Tri-Start PC Tail or Solder Cup Jam Nut

2M805-005-07 and 2M805-017-07

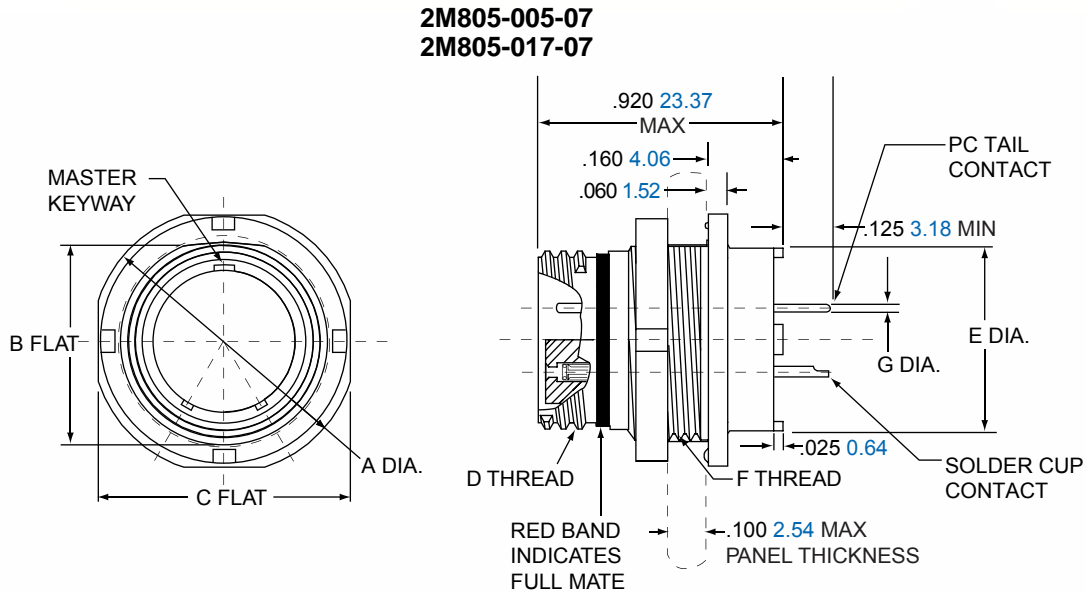

2M805

Shell Size	A Dia.		B Flat		C Flat		D Threads	E Dia.		F Threads	G PC Tail Dia.
	in.	mm.	in.	mm.	in.	mm.		in.	mm.		
8	.760	19.30	.535	13.59	.730	18.54	.5000.1P-.3L-TS-2A	.330	8.38	.5625-28 UNEF-2A	#23 .018/.022 0.46/0.56
9	.880	22.35	.661	16.79	.850	21.59	.5625.1P-.3L-TS-2A	.432	10.97	.6875-28 UN-2A	#20 .024/.028 0.61/0.71
10	.880	22.35	.661	16.79	.850	21.59	.6250.1P-.3L-TS-2A	.493	12.52	.6875-28 UN-2A	
11	.955	24.26	.721	18.31	.925	23.50	.6875.1P-.3L-TS-2A	.551	14.00	.7500-28 UN-2A	#16 .060/.064 1.521/1.63
12	1.060	26.92	.784	19.91	1.035	26.29	.7500.1P-.3L-TS-2A	.620	15.78	.8125-28 UN-2A	
15	1.203	30.56	.970	24.64	1.173	29.79	.9375.1P-.3L-TS-2A	.703	17.86	1.0000-28 UN-2A	#12 .092/.096 2.34/2.44
18	1.389	35.28	1.147	29.13	1.359	34.52	1.1250.1P-.3L-TS-2A	.863	21.92	1.1875-28 UN-2A	
19	1.450	36.83	1.221	31.01	1.420	36.07	1.1875.1P-.3L-TS-2A	.912	23.16	1.2500-28 UN-2A	
23	1.705	43.31	1.470	37.34	1.675	42.55	1.4375.1P-.3L-TS-2A	1.162	29.51	1.500-25 UN-2A	

PANEL CUTOUT FOR JAM NUT

Shell Size	A Flat		B Dia	
	in. ±.002	mm. ± 0.05	in. ±.005	mm. ± 0.13
8	.543	13.79	.572	14.53
9	.669	16.99	.698	17.73
10	.669	16.99	.698	17.73
11	.729	18.51	.760	19.30
12	.792	20.17	.822	20.88
15	.978	24.84	1.010	25.65
18	1.155	29.34	1.198	30.43
19	1.231	31.27	1.260	32.00
23	1.480	37.59	1.510	38.35

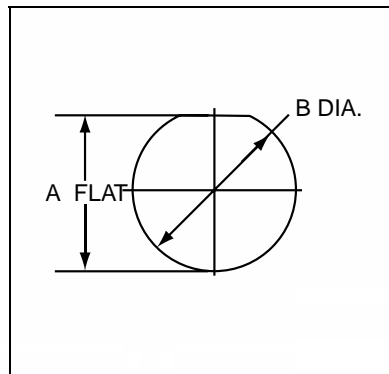

2M805 Tri-Start Hermetic Receptacle

Ordering Guide for 2M805-006

2M805 Series of Hermetic Receptacles:

2M805 Series of Hermetic Receptacles provide superior sealing of 1×10^{-6} cc/second helium leak rate and are 100% tested prior to shipping. This superior sealing is accomplished through the use of glass insulator fused to stainless steel shells and iron alloy contacts.

2M805 FEATURES INCLUDE:

- Low profile shells for minimum box protrusion
- Shell Standoff's for PC Board washout
- Non-removable PC and/or Soldercup contacts
- Hermetic Sealing

Series	Shell Style	Service Class	Shell Size-Insert Arrg.	Contact Type	Alternate Position
2M805-006	-07	Z1	12-26	C	A

SERIES	
2M805-006	Hermetic Receptacle

SHELL STYLE	
-02	Square Flange Receptacle
-03	Solder Mount
-07	Jam Nut for Rear Panel Mounting Receptacle

SHELL SIZE - INSERT ARRANGEMENTS	
See Insert Arrangements on Pages 7-9	

CONTACTS	
P	Pin, Solder Cup
C	Pin, PC Tail

SERVICE CLASS	
	Finish
ZL	Stainless Steel/ Nickel Plated
Z1	Stainless Steel/Passivated

KEYING		
Key Position	Key Rotation	
	A	B
(Normal) A	150°	210°
B	75°	210°
C	95°	230°
D	140°	275°

Receptacle View

2M805

2M805-006-02

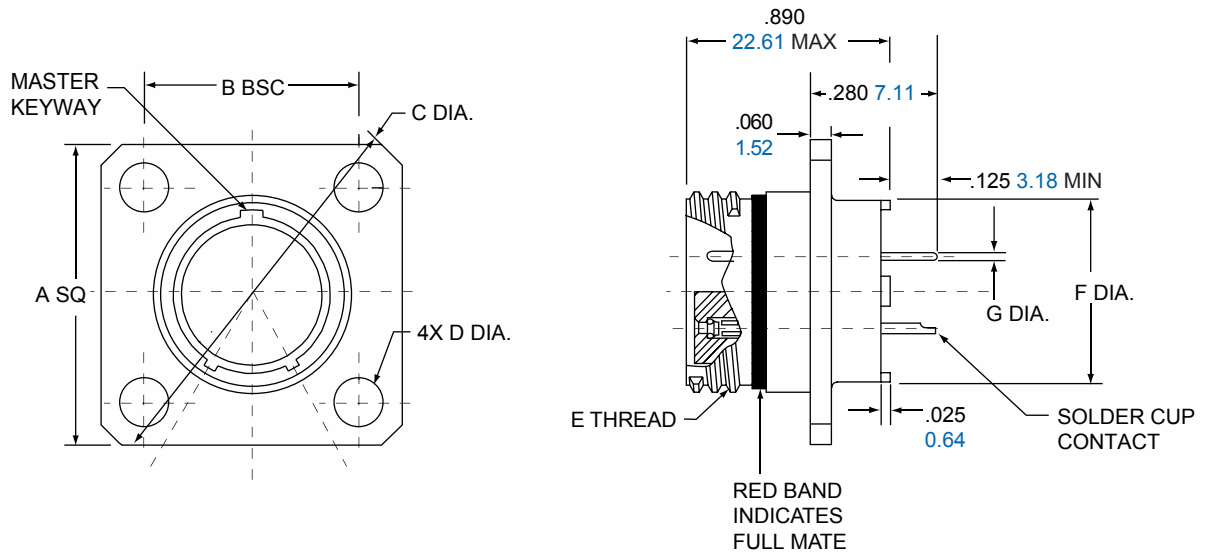

2M805

Shell Size	A Sq.		B BSC.		C Dia.		D Dia.		E Threads	F Dia.		G PC Tail Dia.
	in.	mm.	in.	mm.	in.	mm.	in. ±.003	mm. ±.08		in.	mm.	
8	.850	21.59	.660	16.76	1.150	29.21	.094	2.39	.5000.1P-.3L-TS-2A	.330	8.38	#23 .018/.022 0.46/0.56
9	.913	23.19	.723	18.36	1.230	31.24	.094	2.39	.5625.1P-.3L-TS-2A	.432	10.97	#20 .024/.028 0.61/0.71
10	.975	24.77	.785	19.94	1.330	33.78	.094	2.39	.6250.1P-.3L-TS-2A	.493	12.52	#16 .060/.064 1.521/1.63
11	1.039	26.39	.848	21.54	1.410	35.81	.094	2.39	.6875.1P-.3L-TS-2A	.551	14.00	#12 .092/.096 2.34/2.44
12	1.099	27.91	.909	23.09	1.500	38.10	.094	2.39	.7500.1P-.3L-TS-2A	.620	15.78	
15	1.288	32.74	1.058	26.87	1.750	44.45	.128	3.25	.9375.1P-.3L-TS-2A	.703	17.86	
18	1.475	37.47	1.255	31.88	2.000	50.80	.128	3.25	1.1250.1P-.3L-TS-2A	.863	21.92	
19	1.537	71.06	1.327	33.71	2.094	53.19	.128	3.25	1.1875.1P-.3L-TS-2A	.912	23.16	
23	1.787	45.39	1.570	39.88	2.440	61.98	.128	3.25	1.4375.1P-.3L-TS-2A	1.162	29.51	

2M805 Tri-Start Solder Mount Hermetic

2M805-006-03

2M805-006-03

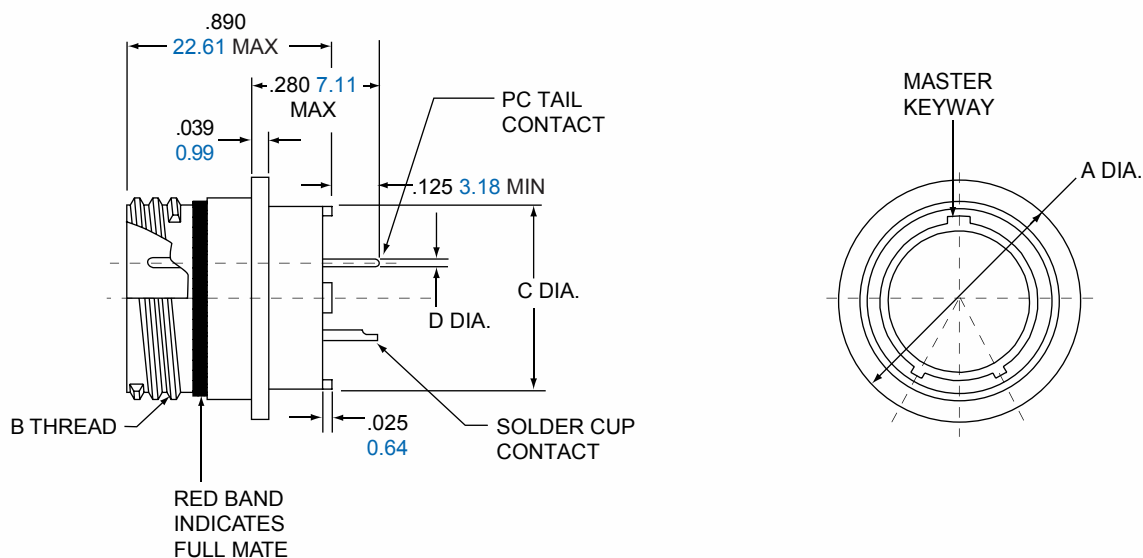

2M805

Shell Size	A Dia.		B Threads	C Dia.		D PC Tail Dia.
	in.	mm.		in.	mm.	
8	.625	15.88	.5000.1P-.3L-TS-2A	.330	8.38	#23 .018/.022 0.46/0.56
9	.688	17.48	.5625.1P-.3L-TS-2A	.432	10.97	#20 .024/.028 0.61/0.71
10	.750	19.75	.6250.1P-.3L-TS-2A	.493	12.52	
11	.812	20.62	.6875.1P-.3L-TS-2A	.551	14.00	#16 .060/.064 1.521/1.63
12	.875	22.23	.7500.1P-.3L-TS-2A	.620	15.78	
15	1.062	26.97	.9375.1P-.3L-TS-2A	.703	17.86	#12 .092/.096 2.34/2.44
18	1.250	31.75	1.1250.1P-.3L-TS-2A	.863	21.92	
19	1.312	33.32	1.1875.1P-.3L-TS-2A	.912	23.16	
23			1.4375.1P-.3L-TS-2A	1.162	29.51	

2M805 Tri-Start Jam Nut Hermetic

2M805-006-07

2M805-006-07

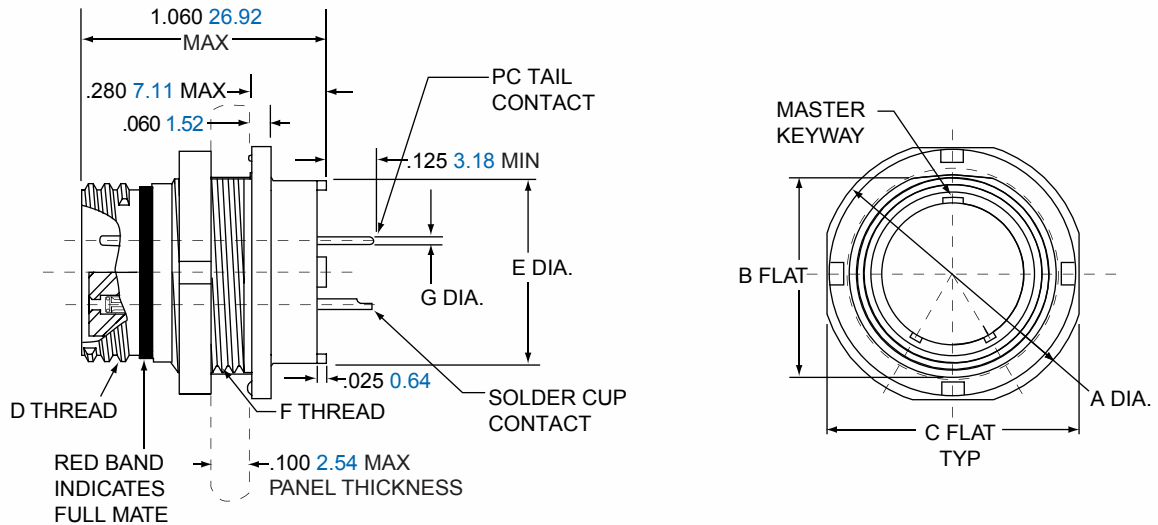

2M805

Shell Size	A Dia.		B Flat		C Flat		D Threads	E Dia.		F Threads	G PC Tail Dia.
	in.	mm.	in.	mm.	in.	mm.		in.	mm.		
8	.760	19.30	.535	13.59	.730	18.54	.5000.1P-.3L-TS-2A	.330	8.38	.5625-28 UNEF-2A	#23
9	.880	22.35	.661	16.79	.850	21.59	.5625.1P-.3L-TS-2A	.432	10.97	.6875-28 UN-2A	.018/.022 0.46/0.56
10	.880	22.35	.661	16.79	.850	21.59	.6250.1P-.3L-TS-2A	.493	12.52	.6875-28 UN-2A	#20
11	.955	24.26	.721	18.31	.925	23.50	.6875.1P-.3L-TS-2A	.551	14.00	.7500-28 UN-2A	.024/.028 0.61/0.71
12	1.060	26.92	.784	19.91	1.035	26.29	.7500.1P-.3L-TS-2A	.620	15.78	.8125-28 UN-2A	#16
15	1.203	30.56	.970	24.64	1.173	29.79	.9375.1P-.3L-TS-2A	.703	17.86	1.0000-28 UN-2A	.060/.064 1.521/1.63
18	1.389	35.28	1.147	29.13	1.359	34.52	1.1250.1P-.3L-TS-2A	.863	21.92	1.1875-28 UN-2A	#12
19	1.450	36.83	1.221	31.01	1.420	36.07	1.1875.1P-.3L-TS-2A	.912	23.16	1.2500-28 UN-2A	.092/.096 2.34/2.44
23	1.705	43.31	1.470	37.34	1.675	42.55	1.4375.1P-.3L-TS-2A	1.162	29.51	1.500-25 UN-2A	

PANEL CUTOUT FOR JAM NUT

Shell Size	A Flat		B Dia	
	in. ±.002	mm. ± 0.05	in. ±.005	mm. ± 0.13
8	.543	13.79	.572	14.53
9	.669	16.99	.698	17.73
10	.669	16.99	.698	17.73
11	.729	18.51	.760	19.30
12	.792	20.17	.822	20.88
15	.978	24.84	1.010	25.65
18	1.155	29.34	1.198	30.43
19	1.231	31.27	1.260	32.00
23	1.480	37.59	1.510	38.35

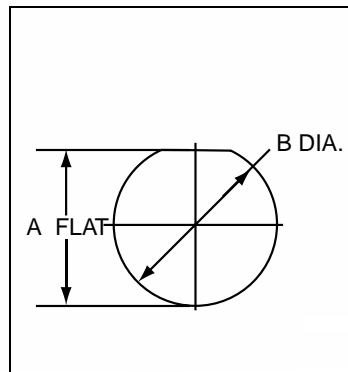

2M805 Tri-Start Protection Cap

Ordering Guide for 2M667-261 and 2M667-262

Series	Service Class	Attachment Type	Shell Size	Attachment Code	Attachment Length in Inches
2M667-26X	-NF	-H	9	04	-5

SERIES	
2M667-261	Protection Caps for 2M805 Plugs
2M667-262	Protection Caps for 2M805 Receptacles

ATTACHMENT TYPE		SHELL SIZE
-G	Nylon Rope	8
-H	Stainless Steel Wire Rope, Teflon® Jacket	9
-N	No Attachment	10
-S	Stainless Steel Sash Chain	11
-SK	Nylon Rope With Slip Knot	12
-T	Stainless Steel Wire Rope, No Jacket	15
-U	Stainless Steel Wire Rope, Polyurethane Jacket	18
		19
		23

Omit for attachment Type N (No Attachment)
Example "-5" equals five inch length

ATTACHMENT CODE	
Omit for attachment Types N (No Attachment) and Slip Knot	
Small Ring	01 – .126 (3.20) I.D. 02 – .145 (3.68) I.D. 04 – .188 (4.78) I.D. 06 – .197 (5.00) I.D.
Large Ring	14 – .385 (9.78) I.D. 16 – .570 (14.48) I.D. 17 – .635 (16.13) I.D. 18 – .695 (17.65) I.D. 19 – .885 (22.48) I.D. 20 – 1.070 (27.17) I.D. 22 – 1.210 (30.73) I.D. 23 – 1.275 (32.39) I.D. 25 – 1.530 (38.86) I.D.
Split Ring	50 – .420 (10.67) I.D. 52 – .480 (12.19) I.D. 54 – .635 (16.13) I.D. 56 – .745 (18.92) I.D. 58 – .885 (22.48) I.D. 60 – 1.010 (25.65) I.D. 64 – 1.125 (28.58) I.D. 68 – 1.345 (34.16) I.D.

SERVICE CLASS		
		Finish
C		Aluminum/Black Anodize (Non-Conductive)
M		Aluminum/Electroless Nickel
NF		Aluminum/Cadmium with Olive Drab Chromate
MT		Aluminum/Nickel-PTFE (Duralon)
Z1		Stainless Steel/Passivated
ZN		Aluminum/Zinc-Nickel w/Olive Drab Chromate
ZNU		Aluminum/Zinc-Nickel with Black Chromate



2M805

2M667-261

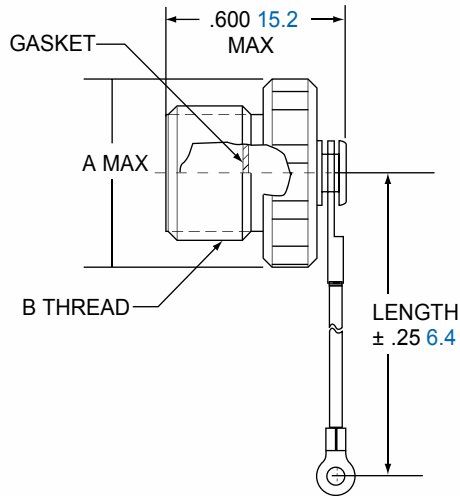

2M667-262

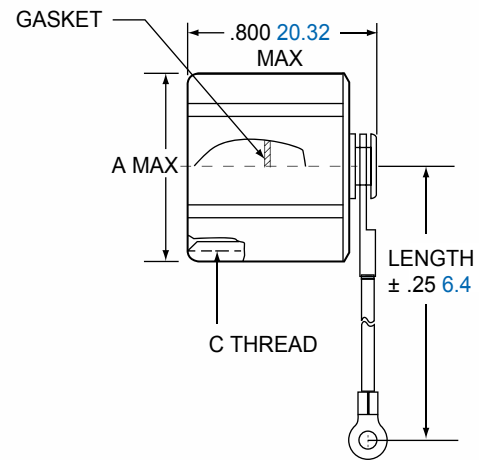





2M805

Shell Size	A Max.		B Thread	C Thread
	in.	mm.		
8	.653	16.59	.5000.1P-.3L-TS-2A	.5000.1P-.3L-TS-2A
9	.715	18.16	.5625.1P-.3L-TS-2A	.5625.1P-.3L-TS-2A
10	.778	19.76	.6250.1P-.3L-TS-2A	.6250.1P-.3L-TS-2A
11	.841	21.36	.6875.1P-.3L-TS-2A	.6875.1P-.3L-TS-2A
12	.903	22.94	.7500.1P-.3L-TS-2A	.7500.1P-.3L-TS-2A
15	1.091	27.71	.9375.1P-.3L-TS-2A	.9375.1P-.3L-TS-2A
18	1.278	32.46	1.1250.1P-.3L-TS-2A	1.1250.1P-.3L-TS-2A
19	1.340	34.04	1.1875.1P-.3L-TS-2A	1.1875.1P-.3L-TS-2A
23	1.600	40.64	1.4375.1P-.3L-TS-2A	1.4375.1P-.3L-TS-2A

MATERIALS AND FINISHES

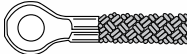
Cover	Aluminum alloy or stainless steel
Gasket	Fluorosilicone rubber
Wire, Hardware	Stainless steel, passivated

LANYARD OPTIONS

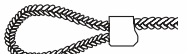
	Nylon Rope	-55° to +100°C., black, flexible, good abrasion resistance, good resistance to fuels, .120" 3mm diameter
	Polyurethane Coated Wire Rope	Black polyurethane over stainless steel rope, very flexible, excellent abrasion resistance, excellent resistance to fuels, .080" 2mm diameter
	Teflon® Jacketed Wire Rope	Translucent FEP jacket over stainless steel, -55° to +200°C., fair flexibility, good abrasion resistance, .100" diameter
	Sash Chain	Stainless steel
	Slip Knot (SK) for attaching Covers to Cables	55° to +100°C., black, flexible, good abrasion resistance, good resistance to fuels, .120" 3mm diameter. Length includes .5" 13mm diameter loop.

Advantages

For 2M Filtered High Density Connectors, Look to the leader...

Amphenol® EMI Protection Connectors have been designed in and manufactured for over 45 years. Our EMI protection connectors offer the versatility of our standard 2M connectors with EMI protection to suit the demands of your application.

ADVANTAGES OF FILTER CONNECTORS

- Reduction in overall weight and space with the elimination of external filtering.
- Reduction in solder joints
- Fewer components equals a cost effective solution with increased reliability
- Eliminates radiated and conducted EMI from entering the box
- Perfect for retrofits or late design-in
- Can utilize standard connector packaging

QUALITY

All filter connectors undergo extensive mechanical and electrical testing to ensure consistent, quality hardware.

STANDARD ELECTRICAL TESTS

- 100% Insulation Resistance testing
- 100% Dielectric Withstanding Voltage testing
- 100% Capacitance testing at 1KHz

OTHER OPTIONS INCLUDE:

- Filtered hermetics
- MOV
- Epoxy backfilled
- Composite
- Diode connectors

SPECIAL TESTS/PROCESSES AVAILABLE

- Attenuation testing (through 100 MHz)
- Leakage inspection
- Thermal cycling/shock
- Burn-in
- De-gassing

Amphenol will work to provide the best solution in standard 2M packaging for the most cost effective solutions available.

RESOURCES

Amphenol Aerospace factory direct: 607.563.5011
Filter Technical Support: FilterApps@Amphenol-aa.com
Web site: www.amphenol-aerospace.com/filters.asp

Note: Below are typical capacitance values. Other capacitance values are available from 5pf to 400 NF in one capacitor element. Please consult factory for part numbers.

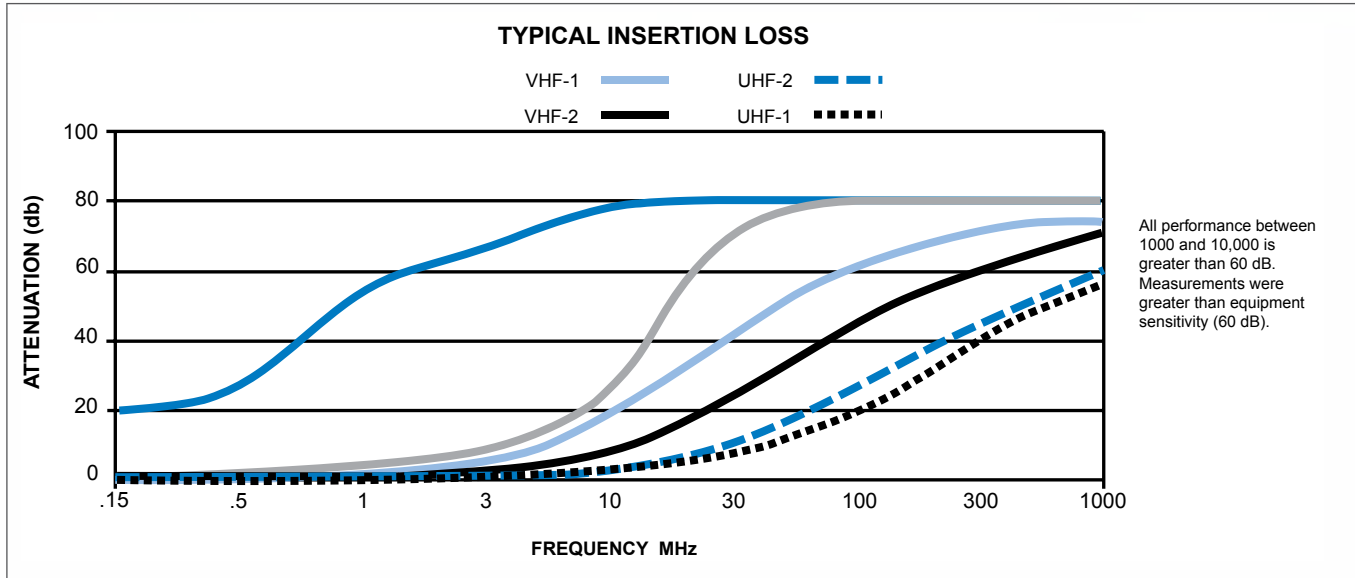

**TYPICAL INSERTION LOSS (dB)
PER MIL-STD-220, 5 ADC, 25°C**

Capacitance	1MHz	3MHz	10MHz	30MHz	100MHz	300MHz	1000MHz
375 pf UHF ₁	0	0	1	8	16	–	–
750 pf UHF ₂	0	0	3	10	19	–	–
2500 pf VHF ₂	0	2	8	20	28	–	–
7000 pf VHF ₁	5	9	17	23	40	–	–

Most filter attenuation curves and capacitance values are expressed at 25°C. However, temperature can affect the capacitance of a titanate filter element, affecting the insertion loss that the element will cause. In order to assist the user in anticipating the effect of various temperatures, the following charts applicable to Amphenol filter connectors utilizing VHF-1, VHF-2, UHF-1 and UHF-2 filters are provided. Please note that all insertion loss (attenuation) values given were measured with no load applied. The band designations refer to MIL-STD-2120.

VHF-1

Typical Capacitance = 7,000 pf Min. 4,900 pf Max. 12,000 pf
Band G, Type Pi

Temp.	F _{co}	1MHz	3MHz	10MHz	30MHz	100MHz	300MHz	1000MHz
-55°C	–	1	2	8	21	44	61	65
Room	1.27M	1	6	18	42	62	72	75
+125°C	–	0	2	9	24	45	62	64

Note: F_{co} = Cut-off Frequency
* Consult Amphenol, Sidney, NY for availability.

VHF-2

Typical Capacitance = 2,500 pf Min. 1,900 pf Max. 4,000 pf
Band E, Type Pi

Temp.	F _{co}	1MHz	3MHz	10MHz	30MHz	100MHz	300MHz	1000MHz
-55°C	–	0	2	7	17	40	58	71
Room	3.3M	0	2	8	24	46	61	71
+125°C	–	0	3	10	26	46	63	69

UHF-1

Typical Capacitance = 375 pf Min. 290 pf Max. 450 pf
Band B, Type Pi

Temp.	F _{co}	1MHz	3MHz	10MHz	30MHz	100MHz	300MHz	1000MHz
-55°C	–	0	0	1	6	21	43	58
Room	21.9M	0	0	1	8	18	42	56
+125°C	–	0	0	1	8	17	38	50

UHF-2

Typical Capacitance = 750 pf Min. 500 pf Max. 1,100 pf
Band C, Type Pi

Temp.	F _{co}	1MHz	3MHz	10MHz	30MHz	100MHz	300MHz	1000MHz
-55°C	–	0	0	3	9	25	46	61
Room	12.7M	0	0	3	10	28	46	61
+125°C	–	0	0	3	10	24	42	60

Please consult the Amphenol Circular Interconnects catalog 12-C3 for full Amphenol EMI/EMP Filter Protection information

2M Series Backshells and Accessories

2M809S060, 2M809A060, Shrink Boots

The 2M series of Shrink boots is intended for use with the 2M series of connectors supplied with Integral Backshells. All Shrink boots are supplied pre coated with Hi temperature, hot melt adhesive that will seal the boot to both the cable and connector. The boots also contain a lip that will lock on to a groove on the connector for improved strain relief.

High Performance Elastomer- Lipped Shrink Boot

- Pre Coated with Adhesive
- Operating Temperature:
-70°C to +150°C
- Rated for 3000hrs.
continuous operation
at +150°C
- Excellent resistance to fuels,
oils, and solvents

Boot Size	Shell Size		Straight Shrink Boots Part Number	Right Angle Boots Part Number
	Series 2M801, 2M803, 2M804	Series 2M805	Pre-Coated with Hi-Temp Hot-Melt Adhesive	Pre-Coated with Hi-Temp Hot-Melt Adhesive
1	5	N/A	2M809S060-1	2M809A060-1
2	6, 7	8,9	2M809S060-2	2M809A060-2
3	8, 9	10,11	2M809S060-3	2M809A060-3
4	10, 12, 13	12, 15	2M809S060-4	2M809A060-4
5	14, 15, 16, 17	18, 19	2M809S060-5	2M809A060-5
6	21	23	2M809S060-6	2M809A060-6

Zero Halogen - Lipped Shrink Boots

- Low Smoke, Zero Halogen
- Toxicity Requirements:
Meets U.S. and EU
standards
- Pre Coated with Adhesive
- Operating Temperature:
-30°C to +125°C
- Good resistance to fuels,
oils, and solvents

Boot Size	Shell Size		Straight Shrink Boot Part Number	Right Angle Shrink Boots Part Number
	Series 2M801, 2M803, 2M804	Series 2M805	Pre-Coated with Hi-Temp Hot-Melt Adhesive	Pre-Coated with Hi-Temp Hot-Melt Adhesive
1	5	N/A	2M809S060-1H	2M809A060-1H
2	6, 7	8,9	2M809S060-2H	2M809A060-2H
3	8, 9	10,11	2M809S060-3H	2M809A060-3H
4	10, 12, 13	12, 15	2M809S060-4H	2M809A060-4H
5	14, 15, 16, 17	18, 19	2M809S060-5H	2M809A060-5H
6	21	23	2M809S060-6H	2M809A060-6H

Size 1 right angle supplied less lip see page 82.

Accessories

Series 2M Torque Values

SERIES 2M801, 2M803, 2M804, 2M805 RECOMMENDED TORQUE VALUES

Shell Size Series 2M801, 2M803, 2M804	Shell Size Series 2M805	Backshell Tightening			
		In-LBs.		N-m	
		Min.	Max.	Min.	Max.
5	-	13	17	1.5	1.9
6	8	18	22	2.0	2.5
7	9	30	40	3.4	4.5
8	10	30	40	3.4	4.5
9	11	35	45	4.0	5.1
10	12	35	45	4.0	5.1
12, 13	15	35	45	4.0	5.1
14, 16	18	35	45	4.0	5.1
15, 17	19	35	45	4.0	5.1
21	23	35	45	4.0	5.1

Lipped Straight Shrink Boots

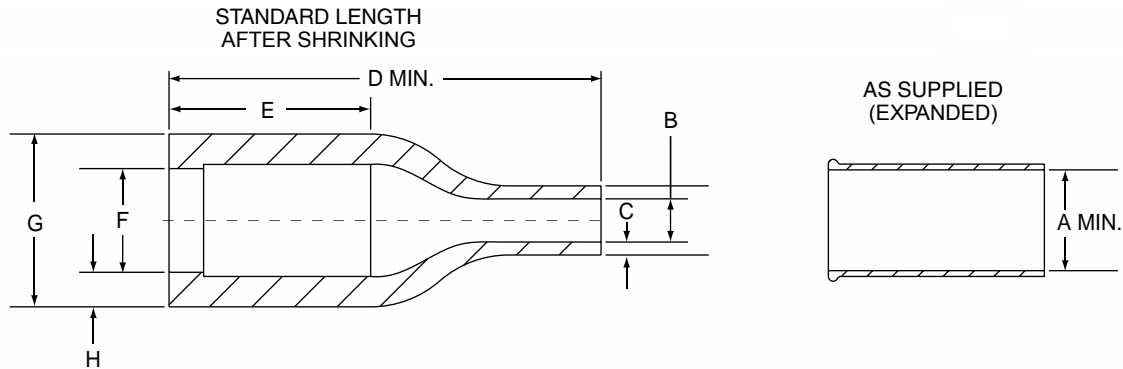

Boot Size	A Min.		B Max.		C±20%		D±10%		E Ref.		F Max.		G Ref.		H±30%	
	in.	mm.	in.	mm.	in.	mm.	in.	mm.	in.	mm.	in.	mm.	in.	mm.	in.	mm.
1	.350	9.0	.080	2.0	.020	0.6	.750	19.0	.350	9.0	.220	5.6	.300	7.6	.040	1.0
2	.650	16.5	.150	3.8	.050	1.3	1.000	25.4	.560	14.2	.310	7.9	.410	10.5	.050	1.3
3	.920	23.4	.220	5.6	.070	1.8	1.500	38.1	0.830	21.1	.410	10.4	.560	14.0	.070	1.8
4	1.120	28.4	.260	6.6	.070	1.8	2.160	54.9	1.090	27.7	.560	14.2	.700	17.8	.070	1.8
5	1.220	31.0	.280	7.1	.080	2.0	2.640	67.0	1.380	35.0	.700	17.8	.860	21.8	.080	2.0
6	1.680	42.7	.390	9.9	.080	2.0	4.080	103.6	2.220	56.4	1.110	28.2	1.270	32.2	.080	2.0

Lipped Right Angle Shrink Boots

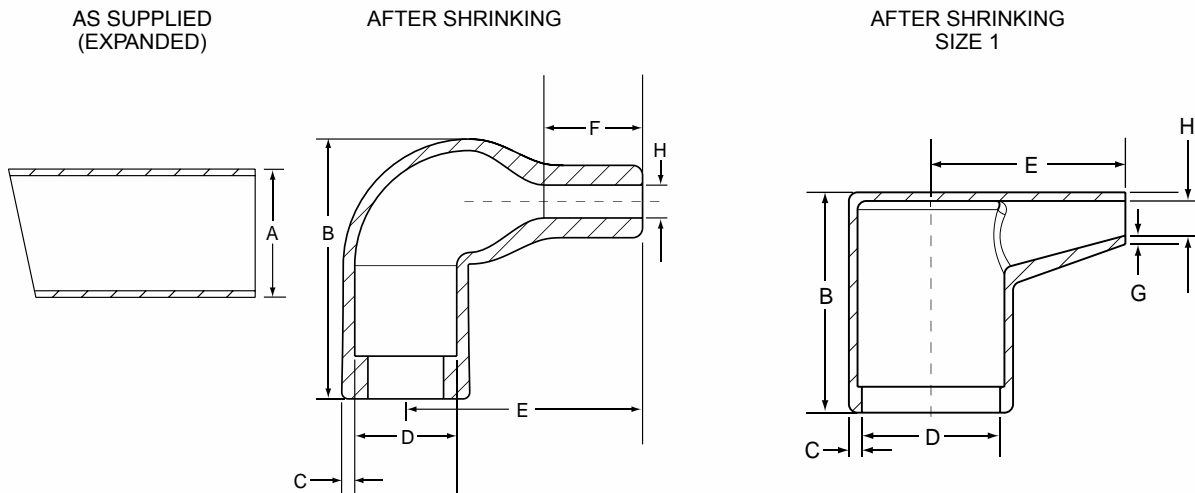

Boot Size	A Min.		B Ref.		C±30%		D Max.		E±20%		F Ref.		G±20%		H Max	
	in.	mm.	in.	mm.	in.	mm.	in.	mm.	in.	mm.	in.	mm.	in.	mm.	in.	mm.
1	.240	6.0	.510	13.0	.040	1.0	.300	7.6	.410	10.5	N/A	N/A	.020	0.5	.080	2.0
2	.650	16.5	.790	20.1	.040	1.0	.310	7.9	.720	18.3	.200	5.1	.060	1.6	.100	2.5
3	.920	23.3	.900	22.9	.050	1.3	.410	10.4	.800	20.3	.230	5.8	.050	1.3	.220	5.6
4	1.120	28.5	1.120	28.5	.060	1.5	.560	14.2	1.170	29.8	.280	7.1	.060	1.5	.250	6.3
5	1.220	30.9	1.200	30.5	.070	1.8	.700	17.8	1.400	35.6	.340	8.6	.070	1.8	.280	7.1
6	1.680	42.6	1.700	43.2	.080	2.0	1.100	27.9	2.100	53.3	.620	15.7	.080	2.0	.380	9.7

2M Backshells and Accessories

Hex Nuts 2M809-035

Hex Jam Nuts for 2M Receptacles

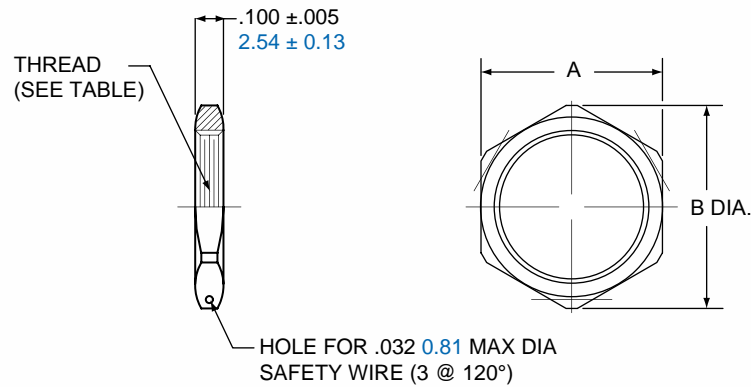

Thread Size Class 2B	Part Number						Dimensions			
	Aluminum				Stainless Steel		A Hex.		B Dia.	
	Electroless Nickel	Olive Drab Cadmium	Black Zinc Nickel	Nickel-PTFE	Passivated	Black Zinc- Cobalt	In.	mm.	In.	mm.
.2500-32 UNEF	2M809-035M01W	2M809-035NF01W	2M809-035ZNU01W	2M809-035MT01W	2M809-035Z101W	2M809-035ZC01W	.375	9.53	.403	10.24
.3125-28 UN	2M809-035M02W	2M809-035NF02W	2M809-035ZNU02W	2M809-035MT02W	2M809-035Z102W	2M809-035ZC02W	.4375	11.11	.475	12.07
.3125-32 UNEF	2M809-035M03W	2M809-035NF03W	2M809-035ZNU03W	2M809-035MT03W	2M809-035Z103W	2M809-035ZC03W	.4375	11.11	.475	12.07
.3750-28 UN	2M809-035M04W	2M809-035NF04W	2M809-035ZNU04W	2M809-035MT04W	2M809-035Z104W	2M809-035ZC04W	.500	12.70	.547	13.89
.4375-28 UNEF	2M809-035M05W	2M809-035NF05W	2M809-035ZNU05W	2M809-035MT05W	2M809-035Z105W	2M809-035ZC05W	.5625	14.29	.620	15.75
.5625-24 UNEF	2M809-035M06W	2M809-035NF06W	2M809-035ZNU06W	2M809-035MT06W	2M809-035Z106W	2M809-035ZC06W	.6875	17.46	.755	19.18
.5625-28 UNEF	2M809-035M16W	2M809-035NF16W	2M809-035ZNU16W	2M809-035MT16W	2M809-035Z116W	2M809-035ZC16W	.6875	17.46	.755	19.18
.5625-32 UN	2M809-035M07W	2M809-035NF07W	2M809-035ZNU07W	2M809-035MT07W	2M809-035Z107W	2M809-035ZC07W	.6875	17.46	.755	19.18
.6250-28 UN	2M809-035M08W	2M809-035NF08W	2M809-035ZNU08W	2M809-035MT08W	2M809-035Z108W	2M809-035ZC08W	.750	19.05	.830	21.08
.6875-28 UN	2M809-035M09W	2M809-035NF09W	2M809-035ZNU09W	2M809-035MT09W	2M809-035Z109W	2M809-035ZC09W	.8125	20.64	.898	22.81
.7500-28 UN	2M809-035M10W	2M809-035NF10W	2M809-035ZNU10W	2M809-035MT10W	2M809-035Z110W	2M809-035ZC10W	.875	22.23	.970	24.64
.8125-28 UN	2M809-035M17W	2M809-035NF17W	2M809-035ZNU17W	2M809-035MT17W	2M809-035Z117W	2M809-035ZC17W	.9375	23.81	1.030	26.16
.8750-28 UN	2M809-035M11W	2M809-035NF11W	2M809-035ZNU11W	2M809-035MT11W	2M809-035Z111W	2M809-035ZC11W	1.000	25.40	1.078	27.38
.9375-20 UNEF	2M809-035M12W	2M809-035NF12W	2M809-035ZNU12W	2M809-035MT12W	2M809-035Z112W	2M809-035ZC12W	1.0625	26.99	1.187	30.15
.9375-28 UN	2M809-035M13W	2M809-035NF13W	2M809-035ZNU13W	2M809-035MT13W	2M809-035Z113W	2M809-035ZC13W	1.0625	26.99	1.187	30.15
1.0000-28 UN	2M809-035M18W	2M809-035NF18W	2M809-035ZNU18W	2M809-035MT18W	2M809-035Z118W	2M809-035ZC18W	1.125	28.58	1.200	30.48
1.0625-20 UN	2M809-035M14W	2M809-035NF14W	2M809-035ZNU14W	2M809-035MT14W	2M809-035Z114W	2M809-035ZC14W	1.1875	30.16	1.264	32.11
1.1250-28 UN	2M809-035M15W	2M809-035NF15W	2M809-035ZNU15W	2M809-035MT15W	2M809-035Z115W	2M809-035ZC15W	1.250	31.75	1.325	33.66
1.1875-28 UN	2M809-035M19W	2M809-035NF19W	2M809-035ZNU19W	2M809-035MT19W	2M809-035Z119W	2M809-035ZC19W	1.3125	33.34	1.415	35.94
1.2500-28 UN	2M809-035M20W	2M809-035NF20W	2M809-035ZNU20W	2M809-035MT20W	2M809-035Z120W	2M809-035ZC20W	1.375	34.93	1.490	37.85
1.5000-28 UN	2M809-035M21W	2M809-035NF21W	2M809-035ZNU21W	2M809-035MT21W	2M809-035Z121W	2M809-035ZC21W	1.625	41.28	1.750	44.45

Accessories

Flange Gaskets for Series 2M801 Receptacles

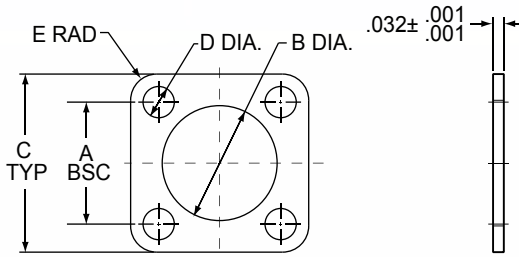

Shell Size	Part Number			A Bsc.		B Dia.		C Typ.		D Dia.		E Rad.	
	Fluorosilicone	Viton®	Conductive Fluorosilicone	in.	mm.	in.	mm.	in.	mm.	in.	mm.	in.	mm.
	5	2M809-108F11	2M809-108V11	2M809-108X11	.363	9.22	.342	8.69	.530	13.46	.093	2.36	.078
6	2M809-108F12	2M809-108V12	2M809-108X12	.423	10.74	.405	10.29	.590	14.99	.093	2.36	.078	1.98
7	2M809-108F13	2M809-108V13	2M809-108X13	.483	12.27	.467	11.86	.650	16.51	.093	2.36	.078	1.98
8	2M809-108F14	2M809-108V14	2M809-108X14	.542	13.84	.530	13.46	.712	18.08	.093	2.36	.078	1.98
9	2M809-108F16	2M809-108V16	2M809-108X16	.719	15.42	.560	14.22	.850	21.59	.125	3.18	.105	2.67
10	2M809-108F15	2M809-108V15	2M809-108X15	.719	17.02	.655	16.64	.890	22.61	.125	3.18	.105	2.67
13	2M809-108F17	2M809-108V17	2M809-108X17	.812	20.62	.842	21.39	1.030	26.16	.125	3.18	.105	2.67
16	2M809-108F18	2M809-108V18	2M809-108X18	.981	24.92	1.030	26.16	1.219	30.96	.125	3.18	.105	2.67
17	2M809-108F19	2M809-108V19	2M809-108X19	1.060	26.92	1.092	27.74	1.280	32.51	.125	3.18	.105	2.67
21	2M809-108F43	2M809-108V43	2M809-108X43	1.322	33.58	1.332	33.83	1.570	39.88	.125	3.18	.105	2.67

Accessories

Flange Gaskets for Series 2M803 Receptacles

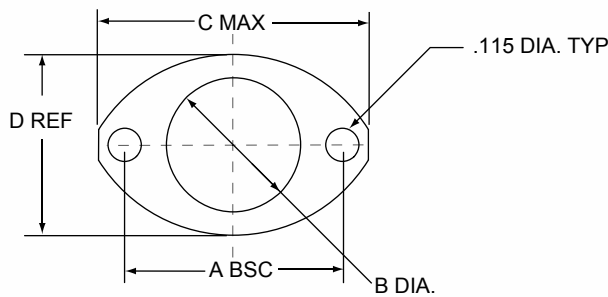

Shell Size	Part Number			A Bsc.		B Dia.		C Max.		D Ref.	
	Fluorosilicone	Viton®	Conductive Fluorosilicone	in.	mm.	in.	mm.	in.	mm.	in.	mm.
	5	2M809-108F31	2M809-108V31	2M809-108X31	.513	13.03	.345	8.00	.710	18.03	.460
6	2M809-108F32	2M809-108V32	2M809-108X32	.598	15.19	.405	10.29	.795	20.19	.522	13.26
7	2M809-108F33	2M809-108V33	2M809-108X33	.708	17.98	.475	12.07	.900	22.86	.590	14.99
8	2M809-108F34	2M809-108V34	2M809-108X34	.964	24.51	.545	13.84	1.160	29.46	.670	17.02
9	2M809-108F35	2M809-108V35	2M809-108X35	1.017	25.83	.605	15.37	1.215	30.86	.721	18.31
10	2M809-108F36	2M809-108V36	2M809-108X36	1.101	37.97	.682	17.32	1.295	32.89	.795	20.19
12	2M809-108F37	2M809-108V37	2M809-108X37	1.204	30.58	.757	19.23	1.400	35.56	.874	22.20
14	2M809-108F38	2M809-108V38	2M809-108X38	1.280	32.51	.910	23.11	1.555	39.50	1.050	26.67
15	2M809-108F39	2M809-108V39	2M809-108X39	1.370	34.80	.970	24.64	1.640	41.66	1.150	29.21

2M Backshells and Accessories

Flange Gaskets 2M809-109

Flange Gaskets for Series 2M805 Receptacles

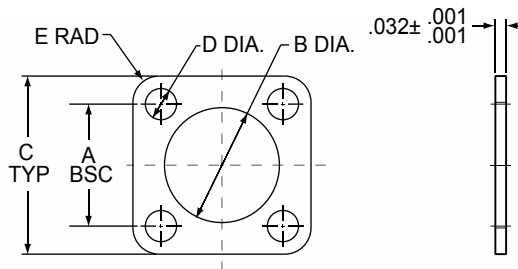

Shell Size	Part Number			A Bsc.		B Dia.		C Typ.		D Dia.		E Rad.	
	Fluorosilicone	Viton®	Conductive Fluorosilicone	in.	mm.	in.	mm.	in.	mm.	in.	mm.	in.	mm.
8	2M809-108F20	2M809-108V20	2M809-108X20	.660	16.76	.530	13.46	.850	13.46	.093	2.36	.078	1.98
9	2M809-108F21	2M809-108V21	2M809-108X21	.723	18.36	.590	14.99	.590	14.99	.093	2.36	.078	1.98
10	2M809-108F22	2M809-108V22	2M809-108X22	.785	19.94	.660	16.76	.660	16.76	.093	2.36	.078	1.98
11	2M809-108F23	2M809-108V23	2M809-108X23	.848	21.54	.720	18.29	.720	18.29	.093	2.36	.078	1.98
12	2M809-108F24	2M809-108V24	2M809-108X24	.909	23.09	.780	19.81	.780	19.81	.093	2.36	.078	1.98
15	2M809-108F25	2M809-108V25	2M809-108X25	1.058	26.87	.970	24.64	.970	24.64	.125	3.18	.105	2.67
18	2M809-108F26	2M809-108V26	2M809-108X26	1.255	31.88	1.160	29.46	1.160	29.46	.125	3.18	.105	2.67
19	2M809-108F27	2M809-108V27	2M809-108X27	1.327	33.71	1.220	30.99	1.220	30.99	.125	3.18	.105	2.67
23	2M809-108F28	2M809-108V28	2M809-108X28	1.570	39.88	1.458	37.03	1.458	37.03	.125	3.18	.105	2.67

O-Rings for Series 2M801 Jam Nut Receptacles

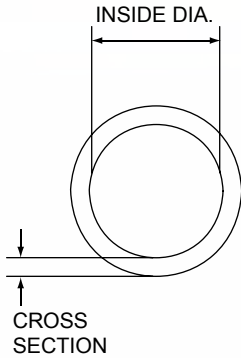

Shell Size	Part Number				Inside Dia.		Cross-Section	
	Fluorosilicone	EPDM	Conductive Silicone Cho-Seal 1285	Conductive Fluorosilicone Cho-Seal 1298	in.	mm.	in.	mm.
5	2M809-054-05F	2M809-054-21F	249-003-801-05B	249-003-801-05C	.394	10.01	.047	1.19
6	2M809-054-06F	2M809-054-06E	249-003-801-06B	249-003-801-06C	.459	11.66	.049	1.24
7	2M809-054-07F	2M809-054-07E	249-003-801-07B	249-003-801-07C	.578	14.68	.040	1.02
8	2M809-054-08F	2M809-054-08E	249-003-801-08B	249-003-801-08C	.578	14.68	.040	1.02
9	2M809-054-09F	2M809-054-09E	249-003-801-09B	249-003-801-09C	.650	16.51	.045	1.14
10	2M809-054-10F	2M809-054-10E	249-003-801-10B	249-003-801-10C	.709	18.01	.043	1.09
13	2M809-054-13F	2M809-054-13E	249-003-801-13B	249-003-801-13C	.894	22.71	.047	1.19
16	2M809-054-16F	2M809-054-16E	249-003-801-16B	249-003-801-16C	1.086	27.58	.040	1.02
17	2M809-054-17F	2M809-054-17E	249-003-801-17B	249-003-801-17C	1.142	29.01	.043	1.09
21	2M809-054-21F	2M809-054-21E	249-003-801-21B	249-003-801-21C				

O-Rings for Series 2M804 Rear Mount Jam Nut Receptacles (Style 07)

Shell Size	Part Number				Inside Diameter		Cross Section	
	Fluorosilicone	EPDM	Conductive Silicone Cho-Seal 1285	Conductive Fluorosilicone Cho-Seal 1298	in.	mm.	in.	mm.
5	2M809-055-05F	2M809-055-05E	249-003-804-05B	249-003-804-05C	.505	12.83	.070	1.78
6	2M809-055-06F	2M809-055-06E	249-003-804-06B	249-003-804-06C	.525	13.34	.071	1.80
7	2M809-055-07F	2M809-055-07E	249-003-804-07B	249-003-804-07C	.638	16.21	.073	1.85
8	2M809-055-08F	2M809-055-08E	249-003-804-08B	249-003-804-08C	.688	17.48	.070	1.78
9	2M809-055-09F	2M809-055-09E	249-003-804-09B	249-003-804-09C	.750	19.05	.070	1.78
10	2M809-055-10F	2M809-055-10E	249-003-804-10B	249-003-804-10C	.813	20.65	.063	1.60
12	2M809-055-12F	2M809-055-12E	249-003-804-12B	249-003-804-12C	.943	23.95	.070	1.78
14	2M809-055-14F	2M809-055-14E	249-003-804-14B	249-003-804-14C	1.061	26.95	.073	1.85
15	2M809-055-15F	2M809-055-15E	249-003-804-15B	249-003-804-15C	1.114	28.30	.070	1.78

O-Rings for Series 2M805 Jam Nut Receptacles

Shell Size	Part Number				Inside Diameter		Cross Section	
	Fluorosilicone	EPDM	Conductive Silicone Cho-Seal 1285	Conductive Fluorosilicone Cho-Seal 1298	in.	mm.	in.	mm.
8	2M809-150-08F	2M809-150-08E	249-003-805-08B	249-003-805-08C	.578	14.68	.040	1.02
9	2M809-150-09F	2M809-150-09E	249-003-805-09B	249-003-805-09C	.709	18.01	.045	1.14
10	2M809-150-10F	2M809-150-10E	249-003-805-10B	249-003-805-10C	.709	18.01	.045	1.14
11	2M809-150-11F	2M809-150-11E	249-003-805-11B	249-003-805-11C	.780	19.81	.047	1.19
12	2M809-150-12F	2M809-150-12E	249-003-805-12B	249-003-805-12C	.894	22.71	.047	1.19
15	2M809-150-15F	2M809-150-15E	249-003-805-15B	249-003-805-15C	1.024	26.01	.047	1.19
18	2M809-150-18F	2M809-150-18E	249-003-805-18B	249-003-805-18C	1.201	30.51	.047	1.19
19	2M809-150-19F	2M809-150-19E	249-003-805-19B	249-003-805-19C	1.257	31.93	.047	1.19
23	2M809-150-23F	2M809-150-23E	249-003-805-23B	249-003-805-23C	1.530	38.86	.047	1.19

2M Strain Relief Clamp Ordering Information

2M620MS064 and 2M920MS065

Part Number	Service Class	Size Code
2M620MS064	-M	07

PART NUMBER	
2M620MS065	Rotatable Coupling
2M620MS064	Direct Coupling

SIZE CODE				
Size Code	Thread Size	Cable Entry Diameter	Shell Size	
			Series 2M801, 2M803, 2M804	Series 2M805
05	.2500-32 UNEF	.11	5	
06	.3125-32 UNEF	.17	6	
11	.3750-32 UNEF	.17		8
07	.4375-28 UNEF	.23	7	9
08	.5000-28 UNEF	.30	8	10
09	.5625-24 UNEF	.30	9	11
10	.6250-24 UNEF	.36	10	12
12	.6875-24 UNEF	.42	12, 13	
13	.7500-20 UNEF	.42		15
14	.9375-20 UNEF	.48	14, 15, 16, 17	18, 19
15	.9375-20 UNEF	.61	14, 15, 16, 17	18, 19
17	1.1875-18 UNEF	.86	21	23



SERVICE CLASS	
	Finish
C	Aluminum/Black Anodize (Non-Conductive)
M	Aluminum/Electroless Nickel
NF	Aluminum/Cadmium with Olive Drab Chromate
MT	Aluminum/Nickel-PTFE (Duralon)
Z1	Stainless Steel/Passivated
ZN	Aluminum/Zinc-Nickel w/Olive Drab Chromate
ZNU	Aluminum/Zinc-Nickel with Black Chromate

MATERIALS

Nut, Clamp, and Saddles	Aluminum Alloy 6061-T6 or 300 Series SST
Hardware	300 Series Stainless Steel

Accessories

2M Strain Relief Clamp Dimensions

2M620MS064 and 2M620MS065

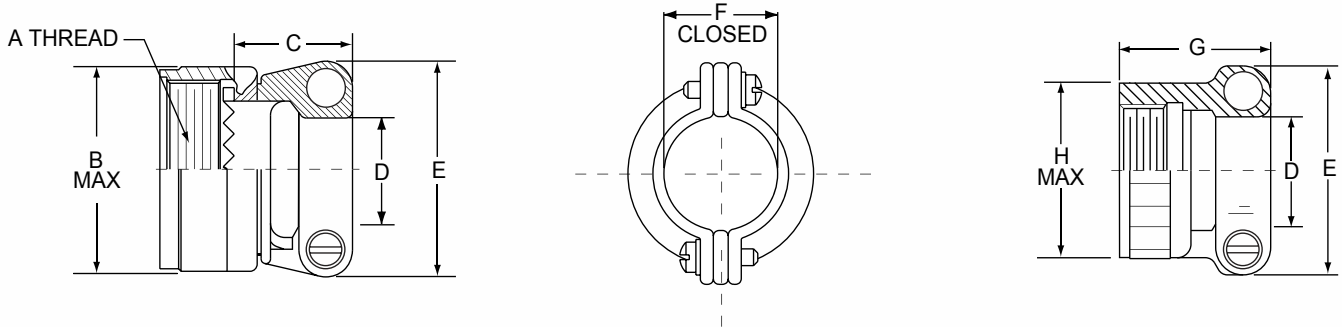

Accessories

Size Code	A Threads UNEF-2B	B Max.		C Max.		D DIA.		E		F		G Max		H Max.	
		in.	mm.	in.	mm.	in. ± .015	mm. ± 0.38	in. ± .015	mm. ± 0.38	in. ± .030	mm. ± 0.76	in.	mm.	in.	mm.
05	.2500-32	.470	11.94	.688	17.48	.119	3.02	.496	12.60	.110	2.79	.625	15.88	.350	8.89
06	.3125-32	.530	13.46	.688	17.48	.182	4.62	.582	14.78	.170	4.32	.625	15.88	.415	10.54
11	.3750-32	.570	14.48	.688	17.48	.182	4.62	.582	14.78	.170	4.32	.625	15.88	.465	11.81
07	.4375-28	.637	16.18	.688	17.48	.244	6.20	.656	16.66	.230	5.08	.688	17.48	.530	13.46
08	.5000-28	.700	17.78	.688	17.48	.307	7.80	.726	18.44	.300	7.62	.688	17.48	.595	15.11
09	.5000-28	.758	19.25	.750	19.05	.307	7.80	.726	18.44	.300	7.62	.750	19.05	.650	16.51
10	.6250-24	.819	20.80	.750	19.05	.369	9.37	.885	22.48	.360	9.14	.875	22.23	.715	18.16
12	.6875-24	.896	22.76	.750	19.05	.423	10.97	.952	24.18	.420	10.67	.875	22.23	.785	19.94
13	.7500-20	.930	23.62	.750	19.05	.432	10.97	.952	24.18	.420	10.67	.875	22.23	.830	21.08
14	.9375-20	1.137	28.88	.750	19.05	.494	12.55	1.018	25.86	.480	12.19	1.000	25.40	1.020	25.91
15	.9375-20	1.137	28.88	.750	19.05	.619	15.72	1.148	29.16	.610	15.49	1.000	25.40	1.020	25.91
17	1.1875-18	1.397	35.48	.750	19.05	.869	22.07	1.400	35.56	.860	21.84	1.125	28.58	1.280	32.51

2M Thread-On BAND-IT® Adapter

Ordering Information 2M440MS135, 2M440MK135 and 2M440ML135

Part Number	Service Class	Size Code	Cable Entry Size	Length	Band Option
2M440M 135	-M	07	-05	6	K

Omit for no band supplied
K adapter is supplied with
BAND-IT® shield termination
band, pre-coiled

PART NUMBER	
2M440MS135	Straight Entry
2M440MK135	45° Entry
2M440ML135	90° Entry

SIZE CODE	
05	.2500-32
06	.3125-32
11	.3750-32
07	.4375-28
08	.5000-28
09	.5625-24
10	.6250-24
12	.6875-24
13	.7500-20
14	.9375-20
17	1.1875-18

CABLE ENTRY SIZE		
02-	.125	05-17
03-	.188	05-17
04-	.250	06-17
05-	.312	07-17
06-	.375	07-17
07-	.438	08-17
08-	.500	09-17
09-	.562	10-17
10-	.625	12-17
11-	.688	14-17
12-	.750	14-17
13-	.812	14-17
14-	.875	14-17

LENGTH	
Straight Entry 2M440MS135 Only	
Length Code	Length (inches)
6	.750
7	.875
8	1.000
9	1.125
10	1.250
11	1.375
12	1.500
13	1.625
14	1.750
15	1.875
17	2.125
18	2.250
19	2.375
20	2.500
Specify Length in increments of .125 inches (3.18 mm.)	



SERVICE CLASS		
		Finish
C		Aluminum/Black Anodize (Non-Conductive)
M		Aluminum/Electroless Nickel
NF		Aluminum/Cadmium with Olive Drab Chromate
MT		Aluminum/Nickel-PTFE (Durmalon)
Z1		Stainless Steel/Passivated
ZN		Aluminum/Zinc-Nickel w/Olive Drab Chromate
ZNU		Aluminum/Zinc-Nickel with Black Chromate

MATERIALS	
Nut, Adapter	Aluminum Alloy or 300 Series SST
Band	300 Series SST
O-Ring	Silicone Elastomer

Shell Size

Accessory Thread	Size Code	Series 2M801	Series 2M803	Series 2M804	Series 2M805
.2500-32 UNEF	05	5	5	5	
.3125-32 UNEF	06	6	6	6	
.3750-32 UNEF	11				8
.4375-28 UNEF	07	7	7	7	9
.5000-28 UNEF	08	8	8	8	10
.5625-24 UNEF	09	9	9	9	11
.6250-24 UNEF	10	10	10	10	12
.6875-24 UNEF	12	13	12	12	
.7500-20 UNEF	13				15
.9375-20 UNEF	14	16,17	14, 15	14, 15	18, 19
1.1875-18 UNEF	17	21			23

Accessories

2M Thread-On BAND-IT® Adapter

2M440MS135, 2M440MK135 and 2M440ML135

STRAIGHT ENTRY ROTATABLE COUPLING 2M440MS135

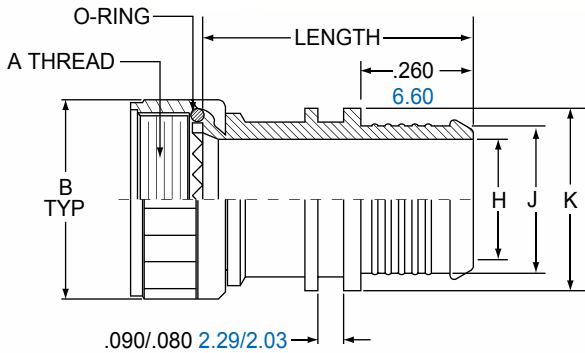

Size Code	A Threads	B Max		C Max.		D Max.		E Max.		F Max.	
		in.	mm.	in.	mm.	in.	mm.	in.	mm.	in.	mm.
05	.2500-32	.470	11.94	.530	13.46	.660	16.76	.630	16.00	.780	19.81
06	.3125-32	.530	13.46	.550	13.97	.670	17.02	.660	16.76	.790	20.27
11	.3750-32	.570	14.48	.580	14.22	.680	17.27	.680	17.27	.810	20.57
07	.4375-28	.637	16.18	.570	14.48	.690	17.53	.700	17.48	.830	21.08
08	.5000-28	.700	17.78	.580	14.73	.700	17.78	.740	18.80	.860	21.84
09	.5625-24	.758	19.25	.590	14.99	.710	18.03	.770	19.56	.890	22.61
10	.6250-24	.819	20.80	.610	15.49	.730	18.54	.800	20.32	.920	23.37
12	.6875-24	.896	22.76	.640	16.26	.750	19.05	.840	21.34	.970	24.64
13	.7500-20	.930	23.62	.660	16.76	.770	19.56	.880	22.35	1.020	25.91
14	.9375-20	1.137	28.88	.690	17.53	.800	20.32	.950	24.13	1.090	27.69
17	1.1875-18	1.387	35.23	.720	18.29	.830	21.08	1.010	25.65	1.160	29.46

45° ENTRY ROTATABLE COUPLING 2M440MK135

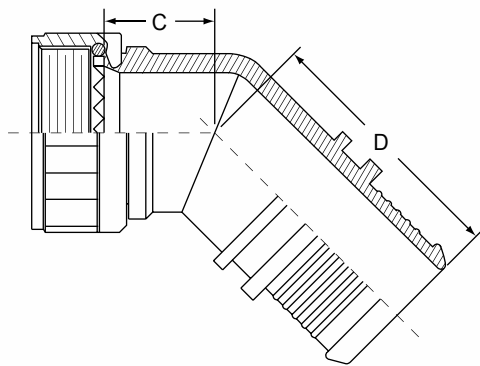

Cable Entry Code	CABLE ENTRY						Use With Size Codes
	H Dia.		J Dia.		K Dia.		
	in. ± .015	mm. ± 0.38	in. ± .015	mm. ± 0.38	in. ± .015	mm. ± 0.38	
02	.125	3.18	.164	4.17	.266	6.76	05-14
03	.188	4.78	.227	5.77	.329	8.36	05-14
04	.250	6.35	.289	7.34	.391	9.93	06-14
05	.312	7.92	.351	8.92	.453	11.51	07-14
06	.375	9.53	.414	10.52	.516	13.11	07-14
07	.438	11.13	.477	12.12	.579	14.71	08-14
08	.500	12.70	.539	13.69	.641	16.28	09-14
09	.562	14.27	.601	15.27	.703	17.86	10-14
10	.625	15.88	.664	16.87	.766	19.46	12-14
11	.688	17.48	.727	18.47	.829	21.06	14
12	.750	19.05	.789	20.04	.891	22.63	14
13	.812	20.62	.851	21.62	.953	24.21	14
14	.875	22.23	.914	23.22	1.016	25.81	14

90° ENTRY ROTATABLE COUPLING 2M440ML135

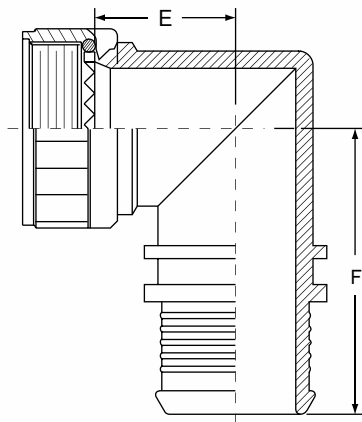

Size Code	A Threads	CONNECTOR SHELL SIZE	
		Shell Size	
		Series 2M801, 2M803, 2M804	Series 2M805
05	.2500-32 UNEF-2B	5	
06	.3125-32 UNEF-2B	6	
11	.375-32 UNEF-2B		8
07	.4375-28 UNEF-2B	7	9
08	.5000-28 UNEF-2B	8	10
09	.5625-24 UNEF-2B	9	11
10	.6250-24 UNEF-2B	10	12
12	.6875-24 UNEF-2B	12, 13	
13	.7500-20 UNEF-2B		15
14	.9375-20 UNEF-2B	14, 15, 16, 17	18, 19
17	1.1875-18 UNEF-2B	21	23

Accessories

2M Low-Profile Adapter Ordering Info

2M440MS134

Part Number	Service Class	Size Code	Cable Entry Size	Length	Band Option
2M440M 135	-M	07	-05	6	K

Omit for no band supplied
K adapter is supplied with
BAND-IT® shield
termination band, pre-coiled

PART NUMBER	
2M440MS134	Straight Entry

SIZE CODE	
05	.2500-32
06	.3125-32
11	.3750-32
07	.4375-28
08	.5000-28
09	.5625-24
10	.6250-24
12	.6875-24
13	.7500-20
14	.9375-20
17	1.1875-18

CABLE ENTRY SIZE		
01	.094	05-06, 11
02	.125	05-07, 11
03	.175	05-08, 11
04	.234	06-08
05	.272	07-09
06	.312	07-10
07	.375	08-13
08	.438	09-13
09	.500	10-13
10	.562	12-14, 17
11	.625	14, 17
12	.688	14, 17
13	.750	14, 17
14	.812	14, 17

LENGTH	
Straight Entry 2M440MS135 Only	
Length Code	Length (inches)
6	.750
7	.875
8	1.000
9	1.125
10	1.250
11	1.375
12	1.500
13	1.625
14	1.750
15	1.875
16	2.000
17	2.125
18	2.250
19	2.375
20	2.500
Specify Length in increments of .125 inches (3.18 mm.)	



SERVICE CLASS		
		Finish
C		Aluminum/Black Anodize (Non-Conductive)
M		Aluminum/Electroless Nickel
NF		Aluminum/Cadmium with Olive Drab Chromate
MT		Aluminum/Nickel-PTFE (Durmalon)
Z1		Stainless Steel/Passivated
ZN		Aluminum/Zinc-Nickel w/Olive Drab Chromate
ZNU		Aluminum/Zinc-Nickel with Black Chromate

MATERIALS

Nut, Adapter	Aluminum Alloy or 300 Series SST
Band	300 Series SST
O-Ring	Silicone Elastomer

Shell Size

Accessory Thread	Size Code	Series 2M801	Series 2M803	Series 2M804	Series 2M805
.2500-32 UNEF	05	5	5	5	
.3125-32 UNEF	06	6	6	6	
.3750-32 UNEF	11				8
.4375-28 UNEF	07	7	7	7	9
.5000-28 UNEF	08	8	8	8	10
.5625-24 UNEF	09	9	9	9	11
.6250-24 UNEF	10	10	10	10	12
.6875-24 UNEF	12	13	12	12	
.7500-20 UNEF	13				15
.9375-20 UNEF	14	16,17	14, 15	14, 15	18, 19
1.1875-18 UNEF	17	21			23

Accessories

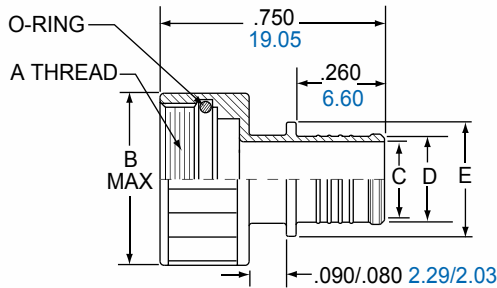

CONNECTOR SHELL SIZE			
Size Code	A Threads	B Max.	
		in.	mm.
05	.2500-32 UNEF-2B	.350	8.89
06	.3125-32 UNEF-2B	.415	10.54
11	.375-32 UNEF-2B	.465	11.81
07	.4375-28 UNEF-2B	.530	13.46
08	.5000-28 UNEF-2B	.595	15.11
09	.5625-24 UNEF-2B	.650	16.51
10	.6250-24 UNEF-2B	.715	18.16
12	.6875-24 UNEF-2B	.785	19.94
13	.750-20 UNEF-2B	.830	21.08
14	.9375-20 UNEF-2B	1.020	25.91
17	1.1875-18 UNEF-2B	1.280	32.51

Cable Entry Code	CABLE ENTRY						Use With Size Codes
	C Dia.		D Dia.		E Dia.		
	in. ± .015	mm. ± 0.38	in. ± .015	mm. ± 0.38	in. ± .015	mm. ± 0.38	
01	.094	2.39	.133	3.38	.235	5.97	05-06
02	.125	3.18	.164	4.17	.266	6.76	05-07
03	.172	4.37	.211	5.36	.313	7.95	05-08
04	.234	5.94	.273	6.93	.375	9.53	06-08
05	.272	6.91	.311	7.90	.413	10.49	07-09
06	.312	7.92	.351	8.92	.453	11.51	07-10
07	.375	9.53	.414	10.52	.516	13.11	08-12
08	.438	11.13	.477	12.12	.579	14.71	09-12
09	.500	12.70	.539	13.69	.641	16.28	10-12
10	.562	14.27	.601	15.27	.703	17.88	12-14
11	.625	15.88	.664	16.87	.766	19.46	14
12	.688	17.48	.727	18.47	.829	21.06	14
13	.750	19.05	.789	20.04	.891	22.63	14
14	.812	20.62	.851	21.62	.953	24.21	14

Size Code	A Threads	CONNECTOR SHELL SIZE	
		Shell Size	
		Series 2M801, 2M803, 2M804	Series 2M805
05	.2500-32 UNEF-2B	5	
06	.3125-32 UNEF-2B	6	
11	.375-32 UNEF-2B		8
07	.4375-28 UNEF-2B	7	9
08	.5000-28 UNEF-2B	8	10
09	.5625-24 UNEF-2B	9	11
10	.6250-24 UNEF-2B	10	12
12	.6875-24 UNEF-2B	12, 13	
13	.750-20 UNEF-2B		15
14	.9375-20 UNEF-2B	14, 15, 16, 17	18, 19
17	1.1875-18 UNEF-2B	21	23

2M Environmental Backshell Ordering Info

2M370MS37, MS038, 2M370MB038, 2M370MA038

Part Number	Service Class	Size Code	Cable Entry Size	Length	Band Option
2M370M 03X	-M	07	-05	6	N

Omit for no band supplied
N Compression Nut, Low Profile

PART NUMBER	
2M370MS038	Straight Entry Rotatable Coupling
2M370MS037	Straight Entry, Direct Coupling
2M370MB038	45° Entry
2M370MA038	90° Entry

SIZE CODE	
05	.2500-32
06	.3125-32
11	.3750-32
07	.4375-28
08	.5000-28
09	.5625-24
10	.6250-24
12	.6875-24
13	.7500-20
14	.9375-20
17	1.1875-18

CABLE ENTRY SIZE		
Code	Max.	Min.
01-	.109	.031
02-	.172	.078
03-	.234	.140
04-	.297	.203
05-	.359	.265
06-	.422	.328
07-	.484	.390
08-	.547	.463
09-	.609	.515

LENGTH	
Straight Entry 2M440MS135 Only	
Length Code	Length (inches)
5	.625
6	.750
7	.875
8	1.000
9	1.125
10	1.250
11	1.375
12	1.500
13	1.625
14	1.750
15	1.875
16	2.000
17	2.125
18	2.250
19	2.375
20	2.500

Specify Length in increments of .125 inches (3.18 mm.)

SERVICE CLASS		
	Finish	
C		Aluminum/Black Anodize (Non-Conductive)
M		Aluminum/Electroless Nickel
NF		Aluminum/Cadmium with Olive Drab Chromate
MT		Aluminum/Nickel-PTFE (Duralon)
Z1		Stainless Steel/Passivated
ZN		Aluminum/Zinc-Nickel w/Olive Drab Chromate
ZNU		Aluminum/Zinc-Nickel with Black Chromate



MATERIALS

Adapter, Clamp, Nut and Saddles	Aluminum Alloy 6061-T6 or 300 Series Stainless Steel
O-Rings	Silicone Rubber
Hardware	300 Series Stainless Steel

Shell Size

Accessory Thread	Size Code	Series 2M801	Series 2M803	Series 2M804	Series 2M805
.2500-32 UNEF	05	5	5	5	
.3125-32 UNEF	06	6	6	6	
.3750-32 UNEF	11				8
.4375-28 UNEF	07	7	7	7	9
.5000-28 UNEF	08	8	8	8	10
.5625-24 UNEF	09	9	9	9	11
.6250-24 UNEF	10	10	10	10	12
.6875-24 UNEF	12	13	12	12	
.7500-20 UNEF	13				15
.9375-20 UNEF	14	16,17	14, 15	14, 15	18, 19
1.1875-18 UNEF	17	21			23

Accessories

2M Environmental Backshell

2M370MS037, MS038, MB038 & MA038

STRAIGHT ENTRY
ROTATABLE COUPLING
2M370MS038

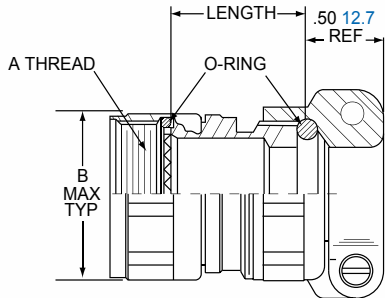

STRAIGHT ENTRY
DIRECT COUPLING
2M370MS037

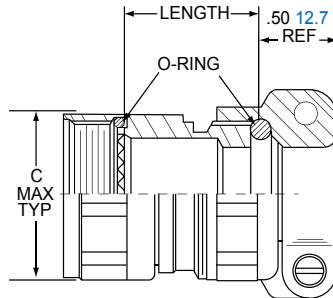

CLAMP STYLE N
COMPRESSION NUT

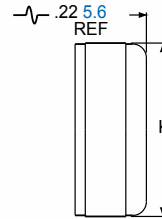

SADDLE CLAMP

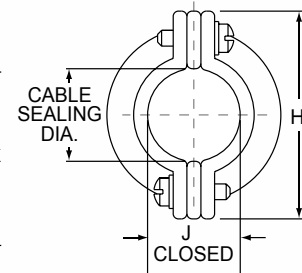

45° ENTRY
ROTATABLE COUPLING
2M370MB038

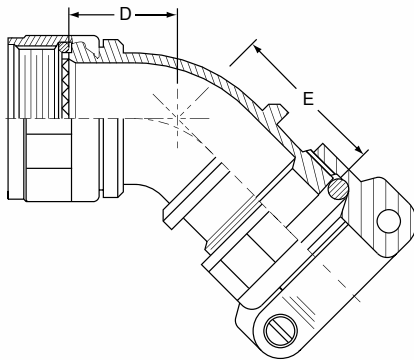

90° ENTRY
ROTATABLE COUPLING
2M370MA038

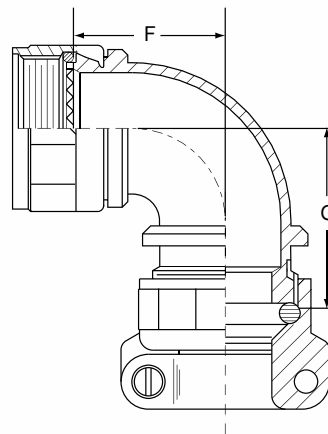

Size Code	A Threads UNEF-2B	B Max.		C Max.		Standard Length*	
		in.	mm.	in.	mm.	in.	mm.
05	.2500-32	.470	11.94	.350	8.89	.750	19.05
06	.3125-32	.530	13.46	.415	10.54	.750	19.05
11	.3750-32	.570	14.48	.465	11.68	.750	19.05
07	.4375-28	.637	16.18	.530	13.46	.750	19.05
08	.5000-28	.700	17.78	.595	15.11	.750	19.05
09	.5000-28	.758	19.25	.650	16.51	.750	19.05
10	.6250-24	.819	20.80	.715	18.16	.750	19.05
12	.6875-24	.896	22.76	.785	19.94	.880	22.35
13	.7500-20	.930	23.62	.830	21.08	.880	22.35
14	.9375-20	1.137	28.88	1.020	25.91	1.000	25.40
17	1.1875-18	1.280	32.51	1.387	35.23	1.130	28.70

*Choose standard length for best availability

Accessories

CABLE ENTRY																
Cable Entry Code	Cable Sealing Dia.		D Max.		E Max.		F Max.		G Max.		H Dia.		J Dia.		K Dia.	
	Max.	Min.	In.	mm.	in.	mm.	in.	mm.	in.	mm.	± .015	± 0.38	± .030	± 0.76	± .015	± 0.38
											in.	mm.	in.	mm.	in.	mm.
01	.109	.031	.603	15.32	.581	14.67	.724	18.39	.702	17.83	.496	12.60	.110	2.79	.398	10.11
02	.172	.078	.603	15.32	.581	14.67	.724	18.39	.702	17.83	.582	14.78	.170	4.32	.460	11.68
03	.234	.140	.603	15.32	.581	14.67	.724	18.39	.702	17.83	.656	16.66	.230	5.84	.523	13.28
04	.297	.203	.629	15.98	.607	15.42	.786	19.96	.764	19.41	.726	18.44	.300	7.62	.585	14.86
05	.359	.265	.629	15.98	.607	15.42	.786	19.96	.764	19.41	.885	22.48	.360	9.14	.647	16.43
06	.422	.328	.655	16.64	.633	16.00	.826	21.54	.826	20.98	.952	24.18	.420	10.67	.710	18.03
07	.484	.390	.655	16.64	.633	16.00	.826	21.54	.826	20.98	1.018	25.86	.480	12.19	.773	19.63
08	.547	.453	.707	17.96	.685	17.40	.889	23.14	.889	22.68	1.084	27.53	.550	13.97	.835	21.21
09	.609	.515	.707	17.96	.685	17.40	.889	23.14	.889	22.58	1.148	29.16	.610	15.49	.897	22.76

2M EMI Backshell Ordering Information

2M380MS137, MS135, 2M380MB137, 2M380MA137

Part Number	Service Class	Size Code	Cable Entry Size	Length	Band Option
2M380M 03	-M	07	-05	6	N

Omit for screw clamp with saddle bars
N Optional Compression Nut, Low Profile

PART NUMBER	
2M380MS137	Straight Entry Rotatable Coupling
2M380MS135	Straight Entry, Direct Coupling
2M380MB137	45° Entry
2M380MA137	90° Entry

SIZE CODE	
05	.2500-32
06	.3125-32
11	.3750-32
07	.4375-28
08	.5000-28
09	.5625-24
10	.6250-24
12	.6875-24
13	.7500-20
14	.9375-20
17	1.1875-18

CABLE ENTRY SIZE	
Code	Saddle Clamp Dia. Fully Closed
01-	.109
02-	.172
03-	.234
04-	.297
05-	.359
06-	.422
07-	.484
08-	.547
09-	.609

LENGTH	
Straight Entry 2M380MS Only	
Length Code	Length (inches)
5	.625
6	.750
7	.875
8	1.000
9	1.125
10	1.250
11	1.375
12	1.500
13	1.625
14	1.750
15	1.875
16	2.000
17	2.125
18	2.250
19	2.375
20	2.500
Specify Length in increments of .125 inches (3.18 mm.)	

SERVICE CLASS	
	Finish
C	Aluminum/Black Anodize (Non-Conductive)
M	Aluminum/Electroless Nickel
NF	Aluminum/Cadmium with Olive Drab Chromate
MT	Aluminum/Nickel-PTFE (Duralon)
Z1	Stainless Steel/Passivated
ZN	Aluminum/Zinc-Nickel w/Olive Drab Chromate
ZNU	Aluminum/Zinc-Nickel with Black Chromate



MATERIALS

Adapter, Clamp, Nut and Saddles	Aluminum Alloy 6061-T6 or 300 Series Stainless Steel
O-Rings	Silicone Rubber
Hardware	300 Series Stainless Steel

Shell Size

Accessory Thread	Size Code	Series 2M801	Series 2M803	Series 2M804	Series 2M805
.2500-32 UNEF	05	5	5	5	
.3125-32 UNEF	06	6	6	6	
.3750-32 UNEF	11				8
.4375-28 UNEF	07	7	7	7	9
.5000-28 UNEF	08	8	8	8	10
.5625-24 UNEF	09	9	9	9	11
.6250-24 UNEF	10	10	10	10	12
.6875-24 UNEF	12	13	12	12	
.7500-20 UNEF	13				15
.9375-20 UNEF	14	16,17	14, 15	14, 15	18, 19
1.1875-18 UNEF	17	21			23

Accessories

2M EMI Backshell

2M380MS137, MS135, MB138 & MA138

STRAIGHT ENTRY
ROTATABLE COUPLING
2M380MS137

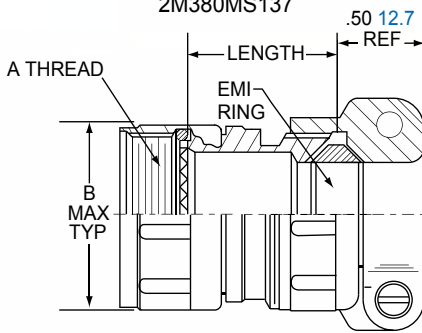

STRAIGHT ENTRY
DIRECT COUPLING
2M380MS135

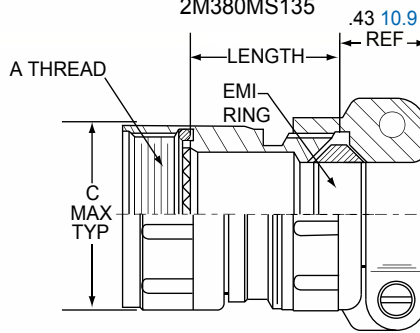

CLAMP STYLE N
COMPRESSION NUT

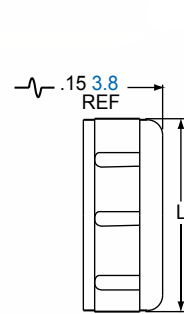

SADDLE CLAMP

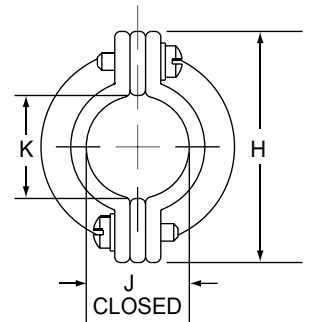

45° ENTRY
ROTATABLE COUPLING
2M380MB137

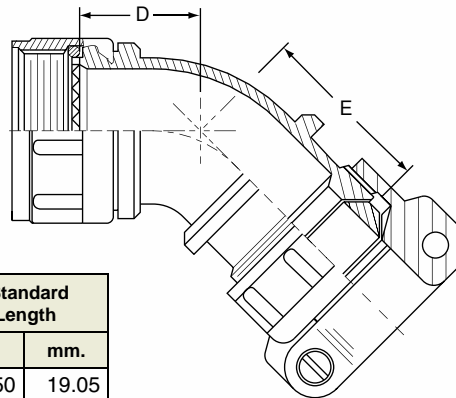

90° ENTRY
ROTATABLE COUPLING
2M380MA137

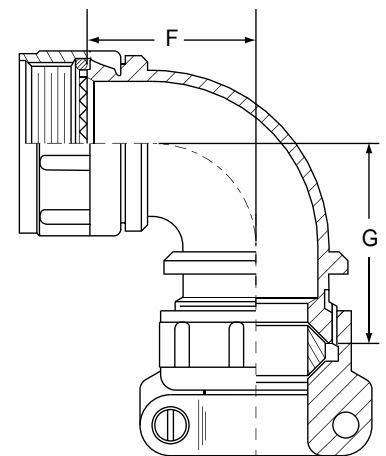

Size Code	A Threads	B Max.		C Max.		*Standard Length	
		in.	mm.	in.	mm.	in.	mm.
05	.2500-32 UNEF-2B	.470	11.94	.350	8.89	.750	19.05
06	.3125-32 UNEF-2B	.530	13.46	.415	10.54	.750	19.05
11	.3750-32 UNEF-2B	.570	14.48	.465	11.68	.750	19.05
07	.4375-28 UNEF-2B	.637	16.18	.530	13.46	.750	19.05
08	.5000-28 UNEF-2B	.700	17.78	.595	15.11	.750	19.05
09	.5000-28 UNEF-2B	.758	19.25	.650	16.51	.750	19.05
10	.6250-24 UNEF-2B	.819	20.80	.715	18.16	.750	19.05
12	.6875-24 UNEF-2B	.896	22.76	.785	19.94	.880	22.35
13	.7500-20 UNEF-2B	.930	23.62	.830	21.08	.880	22.35
14	.9375-20 UNEF-2B	1.137	28.88	1.020	25.91	1.000	25.40
17	1.1875-18 UNEF-2B	1.280	32.51	1.387	35.23	1.130	28.70

*Choose standard length for best availability

Accessories

Cable Entry Code	CABLE ENTRY															
	D Max.		E Max.		F Max.		G Max.		H Dia.		J Dia. Closed		K Dia.		L Dia.	
	in.	mm.	in.	mm.	in.	mm.	in.	mm.	in.	mm.	in.	mm.	in.	mm.	in.	mm.
01	.603	15.32	.581	14.67	.724	18.39	.702	17.83	.496	12.60	.110	2.79	.119	3.02	.398	10.11
02	.603	15.32	.581	14.67	.724	18.39	.702	17.83	.582	14.78	.170	4.32	.182	4.62	.460	11.68
03	.603	15.32	.581	14.67	.724	18.39	.702	17.83	.656	16.66	.230	5.84	.244	6.20	.523	13.28
04	.629	15.98	.607	15.42	.786	19.96	.764	19.41	.726	18.44	.300	7.62	.307	7.80	.585	14.86
05	.629	15.98	.607	15.42	.786	19.96	.764	19.41	.885	22.48	.360	9.14	.369	9.37	.647	16.43
06	.655	16.64	.633	16.00	.848	21.54	.826	20.98	.952	24.18	.420	10.67	.432	10.97	.710	18.03
07	.655	16.64	.633	16.00	.848	21.54	.826	20.98	1.018	25.86	.480	12.19	.494	12.55	.773	19.63
08	.707	17.96	.685	17.40	.911	23.14	.889	22.68	1.084	27.53	.550	13.97	.557	14.15	.835	21.21
09	.707	17.96	.685	17.40	.911	23.14	.889	22.58	1.148	29.16	.610	15.49	.619	15.72	.897	22.76

2M Environmental EMI Backshell Ordering Info

2M390MS077, MS076, 2M380MB077, 2M380MA077

Part Number	Service Class	Size Code	Cable Entry Size	Length	Band Option
2M390M 07X	-M	07	-05	6	N

Omit for screw clamp with saddle bars
N Optional Compression Nut, Low Profile

PART NUMBER	
2M390MS077	Straight Entry Rotatable Coupling
2M390MS076	Straight Entry, Direct Coupling
2M390MB077	45° Entry Rotatable Coupling
2M390MA077	90° Entry Rotatable Coupling

SIZE CODE	
05	.2500-32
06	.3125-32
11	.3750-32
07	.4375-28
08	.5000-28
09	.5625-24
10	.6250-24
12	.6875-24
13	.7500-20
14	.9375-20
17	1.1875-18

CABLE ENTRY SIZE		
Code	Max.	Min.
01-	.109	.031
02-	.172	.078
03-	.234	.140
04-	.297	.203
05-	.359	.265
06-	.422	.328
07-	.484	.390
08-	.547	.463
09-	.609	.515

LENGTH	
Straight Entry 2M390MS Only	
Length Code	Length (inches)
5	.625
6	.750
7	.875
8	1.000
9	1.125
10	1.250
11	1.375
12	1.500
13	1.625
14	1.750
15	1.875
16	2.000
17	2.125
18	2.250
19	2.375
20	2.500
Specify Length in increments of .125 inches (3.18 mm.)	

SERVICE CLASS	
	Finish
C	Aluminum/Black Anodize (Non-Conductive)
M	Aluminum/Electroless Nickel
NF	Aluminum/Cadmium with Olive Drab Chromate
MT	Aluminum/Nickel-PTFE (Duralon)
Z1	Stainless Steel/Passivated
ZN	Aluminum/Zinc-Nickel w/Olive Drab Chromate
ZNU	Aluminum/Zinc-Nickel with Black Chromate



SERIES

Adapter, Clamp, Nut and Saddles	Aluminum Alloy 6061-T6 or 300 Series Stainless Steel
O-Rings	Silicone Rubber
Hardware	300 Series Stainless Steel

Shell Size

Accessory Thread	Size Code	Series 2M801	Series 2M803	Series 2M804	Series 2M805
.2500-32 UNEF	05	5	5	5	
.3125-32 UNEF	06	6	6	6	
.3750-32 UNEF	11				8
.4375-28 UNEF	07	7	7	7	9
.5000-28 UNEF	08	8	8	8	10
.5625-24 UNEF	09	9	9	9	11
.6250-24 UNEF	10	10	10	10	12
.6875-24 UNEF	12	13	12	12	
.7500-20 UNEF	13				15
.9375-20 UNEF	14	16,17	14, 15	14, 15	18, 19
1.1875-18 UNEF	17	21			23

Accessories

2M EMI Backshell

2M390MS077, MS076, MB077 & MA077

STRAIGHT ENTRY
ROTATABLE COUPLING
2M390MS077

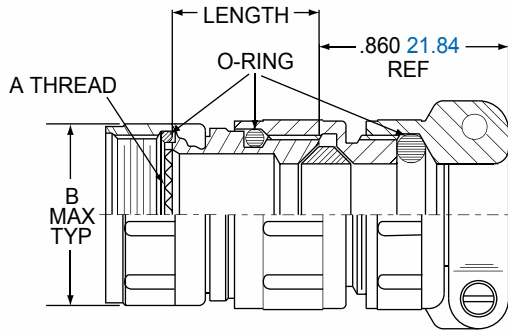

STRAIGHT ENTRY
DIRECT COUPLING
2M390MS076

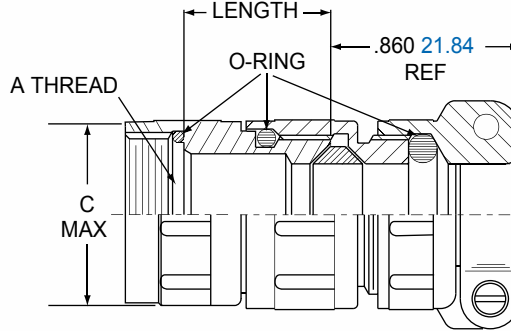

CLAMP STYLE N
COMPRESSION NUT

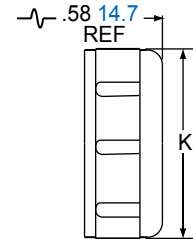

45° ENTRY
ROTATABLE COUPLING
2M390MB077

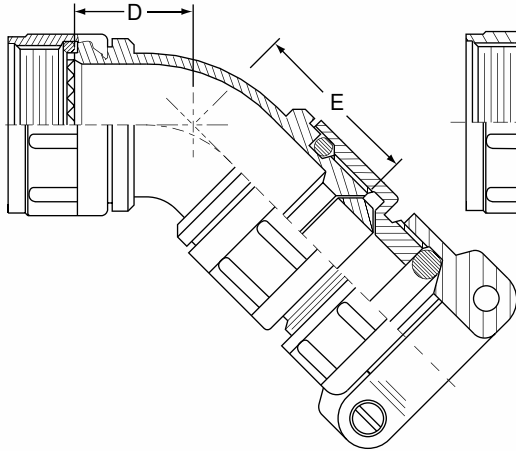

90° ENTRY
ROTATABLE COUPLING
2M390MA077

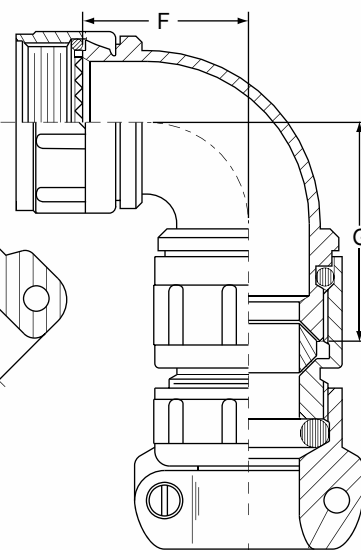

Size Code	A Threads UNEF-2B	B Max.		C Max.		*Standard Length	
		in.	mm.	in.	mm.	in.	mm.
05	.2500-32	.470	11.94	.350	8.89	.750	19.05
06	.3125-32	.530	13.46	.415	10.54	.750	19.05
11	.3750-32	.570	14.48	.465	11.68	.750	19.05
07	.4375-28	.637	16.18	.530	13.46	.750	19.05
08	.5000-28	.700	17.78	.595	15.11	.750	19.05
09	.5625-24	.758	19.25	.650	16.51	.750	19.05
10	.6250-24	.819	20.80	.715	18.16	.750	19.05
12	.6875-24	.896	22.76	.785	19.94	.880	22.35
13	.7500-20	.930	23.62	.830	21.08	.880	22.35
14	.9375-20	1.137	28.88	1.020	25.91	1.000	25.40
17	1.1875-18	1.280	32.51	1.387	35.23	1.130	28.70

*Choose standard length for best availability

SADDLE CLAMP

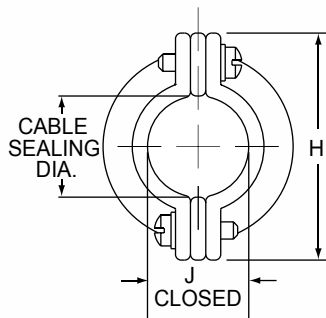

Cable Entry Code	CABLE ENTRY													
	D Max.		E Max.		F Max.		G Max.		H Dia.		J Dia. Closed		K Dia.	
	in.	mm.	in.	mm.	in.	mm.	in.	mm.	± .010	± 0.25	± .030	± 0.76	± .010	± 0.25
01	.603	15.32	.681	14.67	.724	18.39	.802	20.37	.496	12.60	.110	2.79	.398	10.11
02	.603	15.32	.681	14.67	.724	18.39	.802	20.37	.582	14.78	.170	4.32	.460	11.68
03	.603	15.32	.681	14.67	.724	18.39	.802	20.37	.656	16.66	.230	5.84	.523	13.28
04	.629	15.98	.707	15.42	.786	19.96	.864	21.95	.726	18.44	.300	7.62	.585	14.86
05	.629	15.98	.707	15.42	.786	19.96	.864	21.95	.885	22.48	.360	9.14	.647	16.43
06	.655	16.64	.733	16.00	.848	21.54	.926	23.52	.952	24.18	.420	10.67	.710	18.03
07	.655	16.64	.733	16.00	.848	21.54	.926	23.52	1.018	25.86	.480	12.19	.773	19.63
08	.707	17.96	.785	17.40	.911	23.14	.989	25.12	1.084	27.53	.550	13.97	.835	21.21
09	.707	17.96	.785	17.40	.911	23.14	.989	25.12	1.148	29.16	.610	15.49	.897	22.78

Accessories